



CITY OF WOOD DALE

PUBLIC NOTICE

IN ACCORDANCE WITH THE STATUTES OF THE STATE OF ILLINOIS AND THE ORDINANCES OF THE CITY OF WOOD DALE, NOTICE IS HEREBY GIVEN THAT THE CITY COUNCIL WILL CONTINUE ITS REGULAR STANDING COMMITTEE MEETINGS AT 7:30 P.M. ON THURSDAY, SEPTEMBER 22, 2022 IN THE COUNCIL CHAMBERS OF THE CITY HALL, 404 NORTH WOOD DALE ROAD, WOOD DALE, ILLINOIS, FOR THE PURPOSES SET FORTH IN THE FOLLOWING AGENDAS:

STANDING COMMITTEES
OF THE
CITY OF WOOD DALE, ILLINOIS
SEPTEMBER 22, 2022

I. PUBLIC WORKS COMMITTEE

A. Call to Order

B. Roll Call

C. Approval of Minutes of Meeting

- i. September 8, 2022, Public Works Committee Minutes

D. Report and Recommendation

- i. Approval of Purchase Agreements from Landmark Sign Group for Purchase and Installation of City Wayfinding and Entryway Signage in an Amount Not to Exceed \$50,421
- ii. Approval of an Agreement between the City of Wood Dale and Crowne Industries, Ltd. for the Public Works Fuel Tank Replacement Project in an Amount Not to Exceed \$27,969
- iii. Approval of a Purchase Agreement Between the City of Wood Dale and IT Savvy for the Mondo Board Project at City Hall and Public Works in an Amount Not to Exceed \$23,200

E. Items to be Considered at Future Meetings

- i. I & I - TBD

F. Adjournment

POSTED IN CITY HALL ON SEPTEMBER 16, 2022 AT 4:00 PM

LYNN CURIALE, CITY CLERK

BY: MAURA MONTALVO, DEPUTY CITY CLERK



PUBLIC WORKS
COMMITTEE MINUTES

Committee Date: September 8, 2022
Present: Ald. Ames, Ald. Catalano, Ald. Curiale, Ald. Jakab, Ald. Messina, Ald. Susmarski, and Ald. Woods
Absent: None
Also Present: Manager Mermuys, Sgt. Banaszynski, Director Lange, City Clerk Curiale, Treasurer Porch, and Director Staci Springer
Meeting Convened at: 07:31

APPROVAL OF MINUTES:

Ald. Susmarski made a motion, seconded by Ald. Ames, to approve the minutes of the August 11, 2022 meeting as presented. A voice vote was taken, with all members voting aye.

REPORT & RECOMMENDATION

APPROVAL OF PROPOSAL FROM JENSEN'S PLUMBING AND HEATING FOR THE CITY HALL EMERGENCY HVAC REPLACEMENT PROJECT IN AN AMOUNT NOT TO EXCEED \$42,850.00

DISCUSSION:

Ald. Susmarski inquired if this is the final HVAC work to be done. Director Lange said that this is all we have planned at this time. This work was not scheduled, but during inspection it found that the 2 existing roof top units were cracked. Rather than repairing it, it is more cost effective to replace them. No additional work is scheduled at this time, but other parts such as air handlers and other components may need to be replaced down the line. Currently we are working on an inspection schedule for all the roof top units. Ald. Jakabs inquired if we have a maintenance company that would have found this. Director Lange we have a contract with a maintenance company that inspects the units quarterly, and it was at that time the damage was located. The Mayor inquired if we were able to expand the system and connect the Police Department and City Hall systems. Director Lange stated that they are 2 separate systems and we would not be able to connect them.

VOTE:

Ald. Messina made a motion, seconded by Ald. Ames to approve the proposal from Jenson's Plumbing and Heating for the City Hall Emergency HVAC Replacement Project in an amount to exceed \$42,850.00. A roll call vote was taken, with the following results:



Ayes: Ald. Ames, Ald. Catalano, Ald. Curiale, Ald. Jakab, Ald. Messina, Ald. Susmarski, and Ald. Woods
Nays: None
Abstained: None
Motion: Passed

REPORT & RECOMMENDATION

APPROVAL OF AN AGREEMENT BETWEEN THE CITY OF WOOD DALE AND SUPERIOR ROAD STRIPING, INC. FOR THE 2022 PAVEMENT MARKING PROGRAM NOT TO EXCEED \$29,365.00.

DISCUSSION:

Alderman Jakab inquired if we had gotten any other quotes to compare pricing. Director Lange stated that we had compared pricing to last year's bids.

VOTE:

Ald. Messina made a motion, seconded by Ald. Susmarski, to approve an agreement between the City of Wood Dale and Superior Road Striping, Inc. for the 2022 Pavement Marking Program not to exceed, \$29,365.00 A roll call vote was taken, with the following results:

Ayes: Ald. Ames, Ald. Catalano, Ald. Curiale, Ald. Jakab, Ald. Messina, Ald. Susmarski, and Ald. Woods
Nays: None
Abstained: None
Motion: Passed

REPORT & RECOMMENDATION

APPROVAL OF AN AGREEMENT BETWEEN THE CITY OF WOD DALE AND CORRECTIVE ASPHALT MATERIALS FOR PAVEMENT PREVENTATIVE MAINTENANCE IN AN AMOUNT NOT TO EXCEED \$32,883.00

DISCUSSION:

None

VOTE:

Ald. Susmarski made a motion, seconded by Ald. Jakab, to approve an agreement between the City of Wood Dale and Corrective Asphalt Materials for the Pavement Preventative Maintenance in an amount not to exceed \$32,833.00. A roll call vote was taken, with the following results:

Ayes: Ald. Ames, Ald. Catalano, Ald. Curiale, Ald. Jakab, Ald. Messina, Ald. Susmarski, and Ald. Woods
Nays: None
Abstained: None
Motion: Passed

REPORT & RECOMMENDATION

APPROVAL OF AN AGREEMENT BETWEEN THE CITY OF WOOD DALE AND GLOBE CONSTRUCTION, INC. FOR THE FY 2023 SIDEWALK REPLACEMENT PROGRAM IN AN AMOUNT NOT TO EXCEED \$49,992.00

DISCUSSION:

Alderman Catalano inquired if we currently have a program for sinking sidewalk squares, and if we looked in the cost of raising them instead of replacing them. Alderman Lange states that we found that it is generally less expensive to replace them than trying to raise them. Yearly we go around and do a survey throughout town to locate damaged squares. If any squares are brought to your attention, we can send someone out to do an inspection, and we would add them to the list. Alderman Jakab inquired about a couple of squares were located on Arbor Ln., and why we are replacing them if they are relatively new. Director Lange stated that he would investigate the squares condition. Alderman Ames inquired to when the program is scheduled to begin. Director Lange stated that it is scheduled to begin shortly after the project bid is accepted, which is October 6th.

VOTE:

Ald. Messina made a motion, seconded by Ald. Curiale, to approve an agreement between the City of Wood Dale and Globe Construction, Inc. for the FY 2023 Sidewalk Replacement Program in an amount not to exceed \$49,992.00. A roll call vote was taken, with the following results:

Ayes: Ald. Ames, Ald. Catalano, Ald. Curiale, Ald. Jakab, Ald. Messina, Ald. Susmarski, and Ald. Woods
Nays: None
Abstained: None
Motion: Passed

ITEMS TO BE CONSIDERED AT FUTURE MEETINGS:

- Fuel Tank Replacement – September 22
- City Sign Program – September 22



ADJOURNMENT:

Ald. Woods made a motion, seconded by Ald. Susmarski, to adjourn the meeting at 7:45 p.m. Upon a voice vote, the motion carried unanimously.

Minutes taken by Julie Szabo



REQUEST FOR COMMITTEE ACTION

Referred to Committee: September 22, 2022
Subject: City Signage
Staff Contact: Wilvert Ibares, Administrative Services Director
Alan Lange, Public Works Director
Department: Administrative Services and Public Works

TITLE: Approval of Purchase Agreements from Landmark Sign Group for Purchase and Installation of City Wayfinding and Entryway Signage in an Amount Not to Exceed \$50,421

RECOMMENDATION:

Staff Recommends Approval of Purchase Agreements from Landmark Sign Group for Purchase and Installation of City Wayfinding and Entryway Signage in an Amount Not to Exceed \$50,421.

BACKGROUND:

The City Council, as part of the 2021 Strategic Planning Session, tasked staff with developing a wayfinding sign network throughout the City to identify key locations such as Park District, Library District, Fire District, and City facilities. Staff has been working with Landmark Sign Group who has provided previous signage with the City's branding to develop proofs and purchase agreements. The proposed locations, proofs, and purchase agreements of the wayfinding signs are attached, as is the proof and purchase agreement for the entryway sign to be installed near Irving Park Road and Edgewood Avenue.

ANALYSIS:

The total cost of the purchase agreements amounts to \$50,421. Staff budgeted \$75,000 within the Tourism Fund for Community Signage. Wayfinding signs will be mounted to existing streetlights where possible, however some locations may require new poles which would be purchased separately and installed by Public Works staff. The exact location of the Irving Park Road entryway sign will need to be coordinated with existing utilities, signage, driveways, sightlines, and trees. To avoid damage from plows, the sign will need to be located adequate distance from the roadway which may require temporary or permanent easements from private property owners.

DOCUMENTS ATTACHED

- ✓ Wayfinding Map
- ✓ Wayfinding Sign Proofs
- ✓ Entryway Sign Proof
- ✓ Wayfinding Sign Purchase Agreement
- ✓ Entryway Sign Purchase Agreement



By signing the **Customer Acceptance** on this print, I understand that I am accepting all aspects of this drawing. This includes Artwork, Specifications, Dimensions, Spelling, and all other representations herein. I also understand that color reproductions on this print are approximate, and may not match manufacture samples exactly.

X Customer Acceptance SIGNATURE DATE

X IF REQUIRED: Landlord Acceptance SIGNATURE DATE

L.S.G SALES INITIALS DATE



Landmark Sign group

www.landmarksign.com
 7424 Industrial Avenue
 Chesterton, IN 46304
 office 219.762.9577
 direct 574.252.9247

PRINT #
KB-26449-7

KEITH BERINGER, JR.
 LSG SALES REPRESENTATIVE

01.12.2022
 DATE

CITY OF WOOD DALE
 CLIENT NAME

WOOD DALE, IL
 JOB LOCATION

LS AS NOTED
 DRAWN BY SCALE

REVISIONS:
 1.
ML-25358-1/19
ML-25358-2/19

E509514

Designed for 110/277 Volts
 Electrical Connection will be Visible within 5 Ft. of time of installation; Second Trip will be Charged at Time & Material

© 2022 LANDMARK SIGN PARTNERS LLC. This drawing is the property of Landmark Sign Partners LLC. No reproductions or exhibitions are permitted without the express written consent of Landmark Sign Partners LLC. An assessment of up to \$250.00 will be charged for any revision of this drawing.

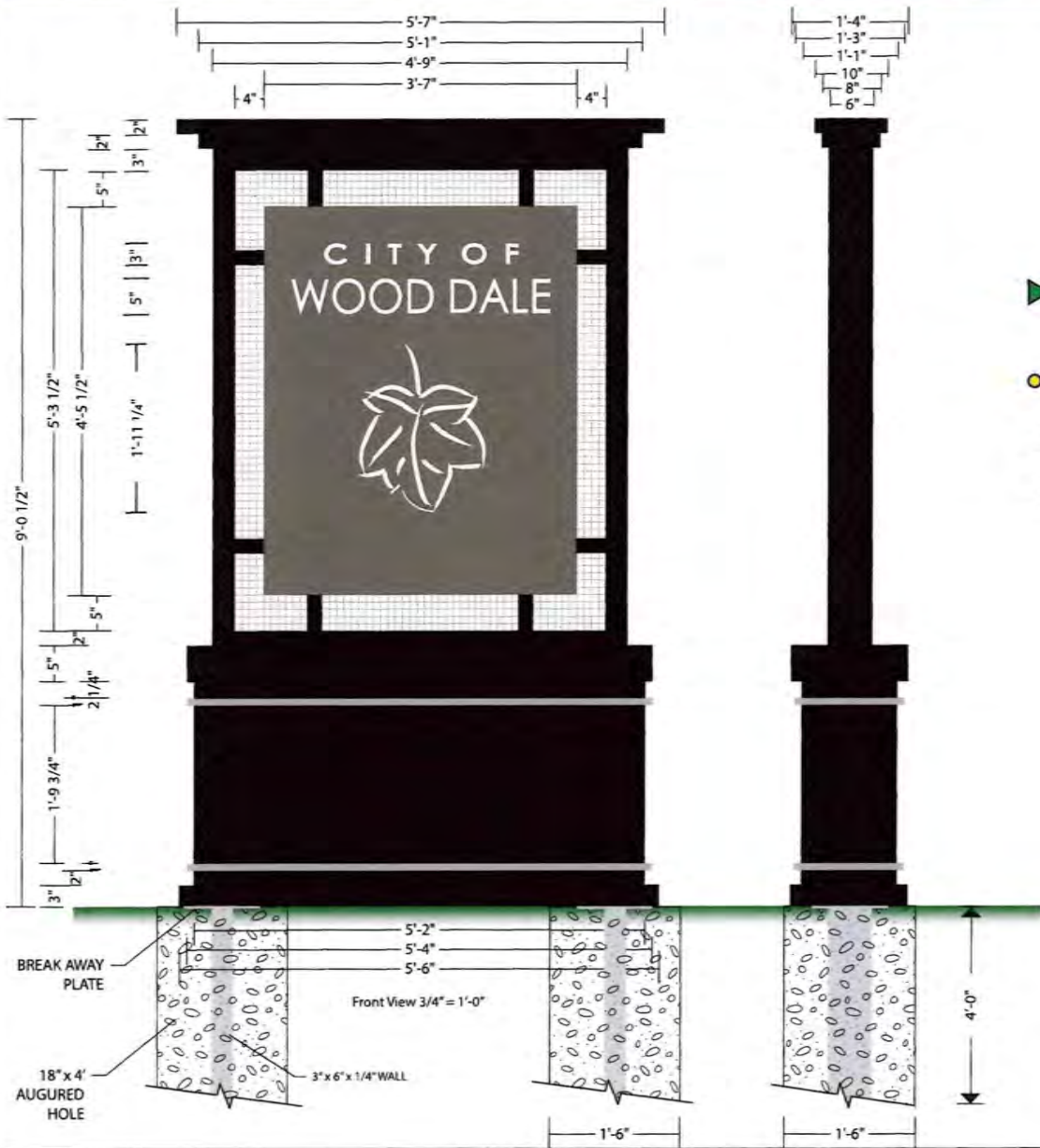

- ▶ **ONE (1) DOUBLE FACE ILLUMINATED ROUTED SHOEBOX FACE SIGN CAN with PERFORATED METAL and ALUMINUM TUBE FRAME**
- **TUBE FRAMING, POLE COVER, CORNICE, REVEALS= MAP BLACK**
- **1" POLE COVER REVEALS = MAP BRUSHED ALUMINUM**
- **PERFORATED METAL = STAINLESS**
- **SIGNCASE = PAINTED SATIN MAP MP10206 LEAD PIPE**
- **COPY & LOGO = 3/4" MILK WHITE ACRYLIC**
- **ILLUMINATION = 6500K WHITE LED**



Back View - N.T.S.

By signing the **Customer Acceptance** on this print, I understand that I am accepting all aspects of this drawing. This includes Artwork, Specifications, Dimensions, Spelling, and all other representations herein. I also understand that color reproductions on this print are approximate, and may not match manufactures samples exactly.

X
Customer Acceptance SIGNATURE DATE

X
 IF REQUIRED: **Landlord Acceptance SIGNATURE** DATE

L.S.G SALES INITIALS DATE

Landmark Sign group

www.landmarksign.com

7424 Industrial Avenue
 Chesterton, IN 46304

office 219.762.9577
 direct 574.252.9247

PRINT #
KB-26449-6A

KEITH BERINGER, JR.
 LSG SALES REPRESENTATIVE

01.31.2022
 DATE

CITY OF WOOD DALE
 CLIENT NAME

WOOD DALE, IL
 JOB LOCATION

LS **AS NOTED**
 DRAWN BY SCALE

REVISIONS:

| |
|----|
| 1. |
|----|

RW-22572-1/15
SE-24203-1/17

UL SAFETY-US
 E509514

Designed for 110/277 Volts
 Electrical Connection will be Visible within 5 Ft. at time of Installation; Second Trip will be Charged at Time & Material

© 2022 LANDMARK SIGN PARTNERS LLC. This drawing is the property of Landmark Sign Partners LLC. No reproductions or exhibitions are permitted without the express written consent of Landmark Sign Partners LLC. An assessment of up to \$2500.00 will be charged for any drawing.

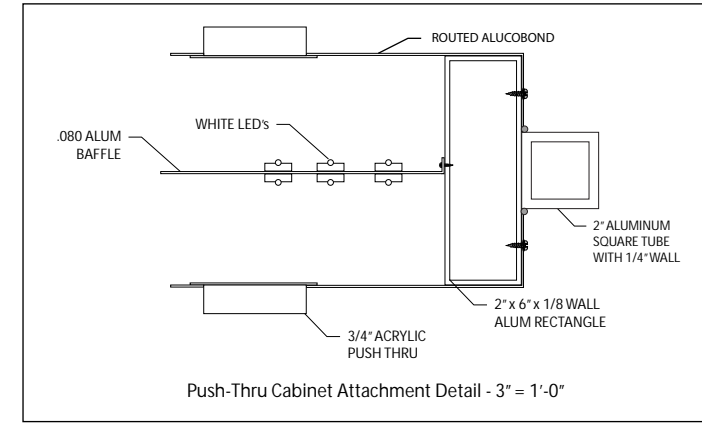

- ▶ **TWO (2) DOUBLE FACE NON ILLUMINATED .080 ALUMINUM PANELS MOUNTED TO 2" ALUMINUM TUBE FRAME with PERFORATED METAL ATTACHED TO EXISTING POLE with CUSTOM BRACKETS**
- **TUBE FRAME / MOUNTING BRACKETS= PAINTED SATIN MAP BLACK**
PERFORATED METAL = STAINLESS
TOP PANEL BKGD = PAINTED SATIN MAP BLACK
BOTTOM PANEL BKGD = PAINTED SATIN MAP MP10206 LEAD PIPE
LOGO / COPY = 7725-010 WHITE OPAQUE VINYL

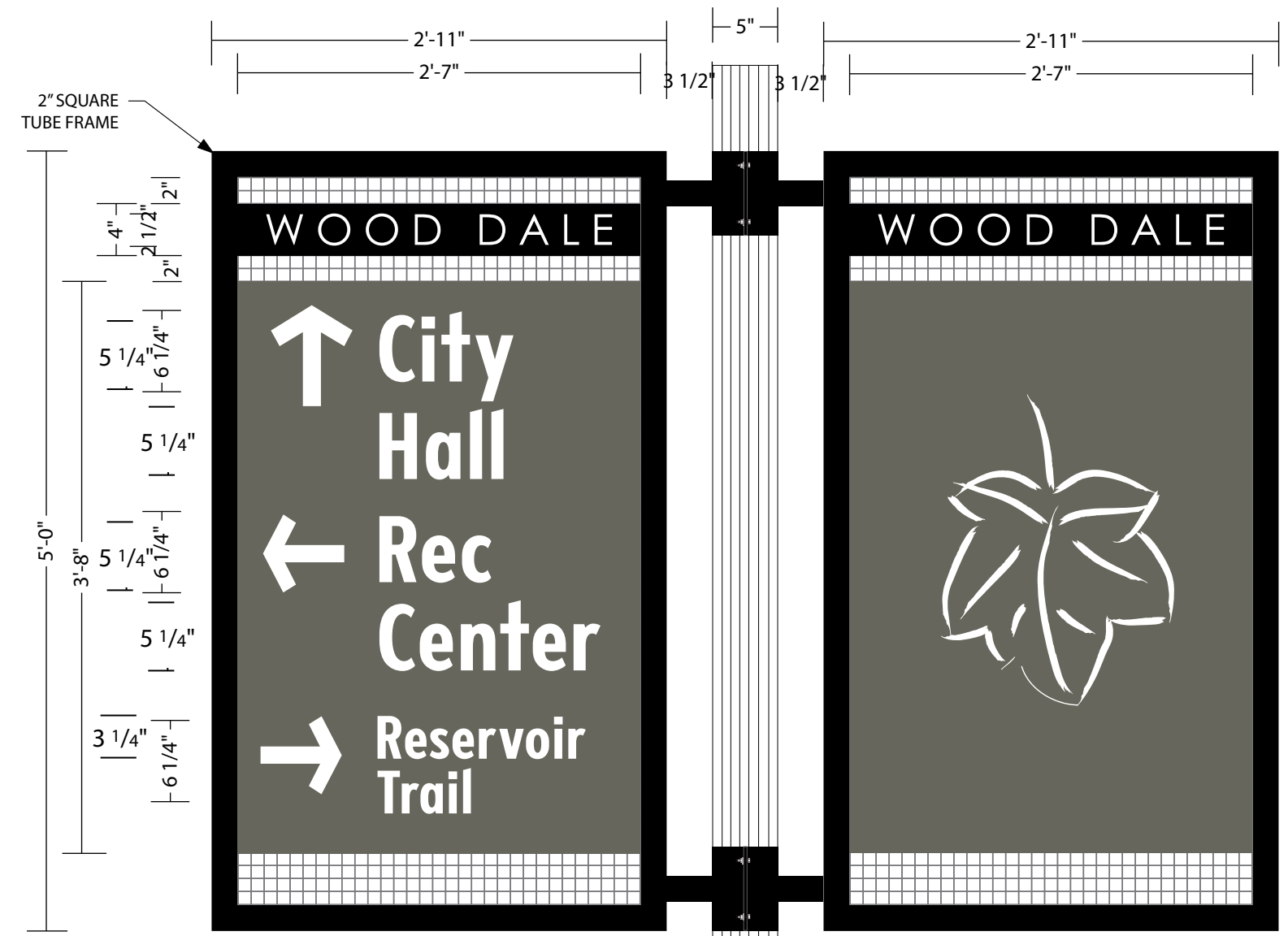

Front View 1" = 1'-0"

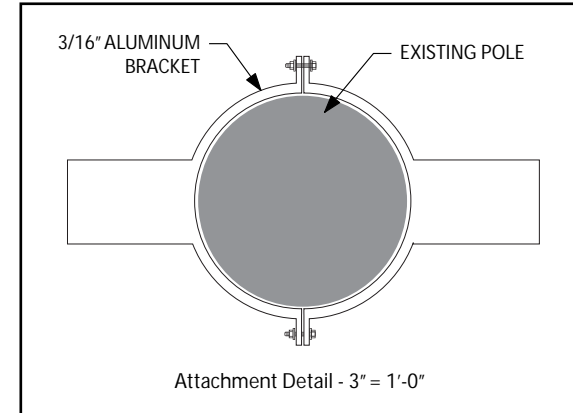

Attachment Detail - 3" = 1'-0"

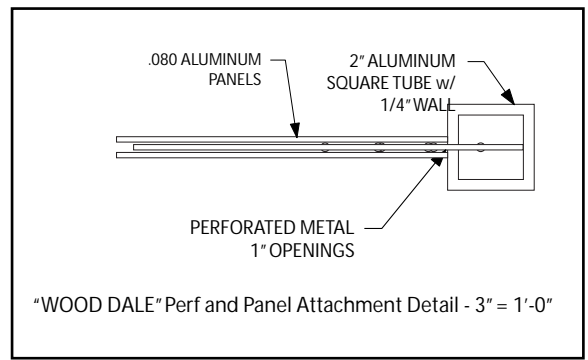

WOOD DALE Perf and Panel Attachment Detail - 3" = 1'-0"



Back View - N.T.S.

By signing the **Customer Acceptance** on this print, I understand that I am accepting all aspects of this drawing. This includes Artwork, Specifications, Dimensions, Spelling, and all other representations herein. I also understand that color reproductions on this print are approximate, and may not match manufactures samples exactly.

X
Customer Acceptance SIGNATURE DATE

X
 IF REQUIRED: **Landlord Acceptance SIGNATURE** DATE

L.S.G SALES INITIALS DATE

Landmark Sign group

www.landmarksign.com

7424 Industrial Avenue
 Chesterton, IN 46304

office 219.762.9577
 direct 574.252.9247

PRINT #
KB-26449-6B

KEITH BERINGER, JR.
 LSG SALES REPRESENTATIVE

01.31.2022
 DATE

CITY OF WOOD DALE
 CLIENT NAME

WOOD DALE, IL
 JOB LOCATION

LS AS NOTED
 DRAWN BY SCALE

REVISIONS:

1.

RW-22572-1/15
SE-24203-1/17

UL SAFETY-US
E509514

Designed for 110/277 Volts

Electrical Connection will be Visible within 5 Ft. at time of Installation; Second Trip will be Charged at Time & Material

© 2022 LANDMARK SIGN PARTNERS LLC. This drawing is the property of Landmark Sign Partners LLC. No reproductions or exhibitions are permitted without the express written consent of Landmark Sign Partners LLC. An assessment of up to \$2500.00 will be charged for this drawing.

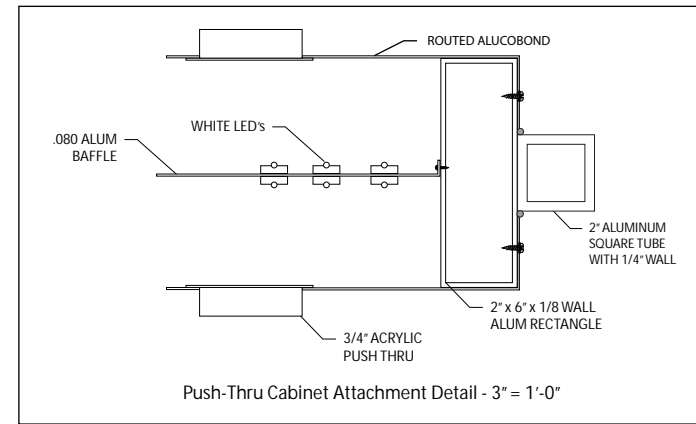

- ▶ **TWO (2) DOUBLE FACE NON ILLUMINATED .080 ALUMINUM PANELS MOUNTED TO 2" ALUMINUM TUBE FRAME with PERFORATED METAL ATTACHED TO EXISTING POLE with CUSTOM BRACKETS**
- **TUBE FRAME / MOUNTING BRACKETS= PAINTED SATIN MAP BLACK**
PERFORATED METAL = STAINLESS
TOP PANEL BKGD = PAINTED SATIN MAP BLACK
BOTTOM PANEL BKGD = PAINTED SATIN MAP MP10206 LEAD PIPE
LOGO / COPY = 7725-010 WHITE OPAQUE VINYL

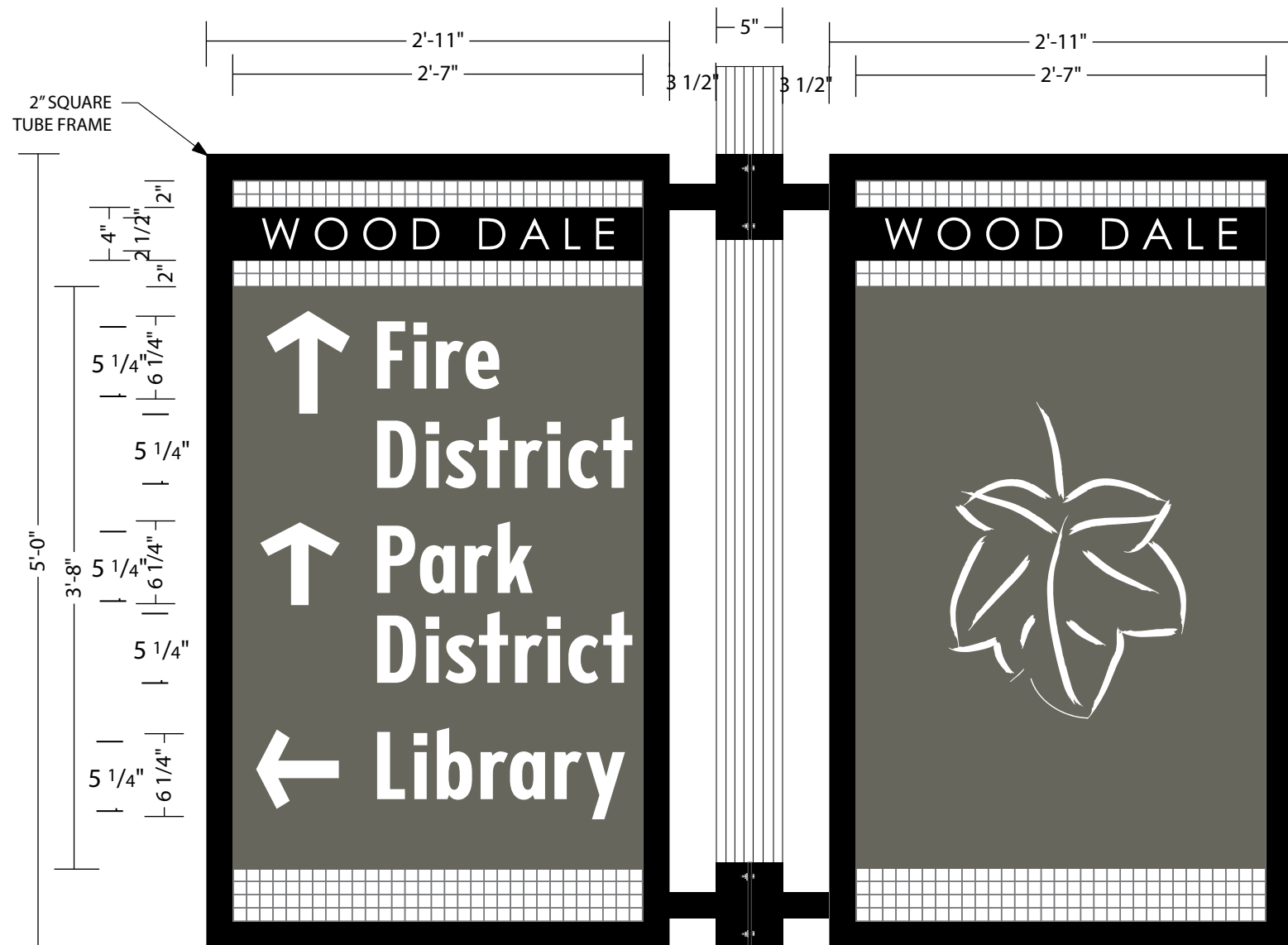

Front View 1" = 1'-0"

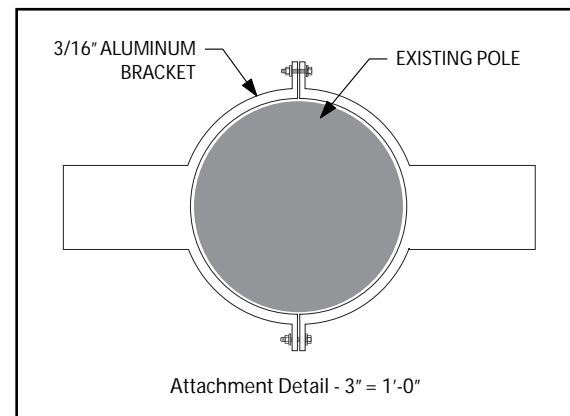

Attachment Detail - 3" = 1'-0"

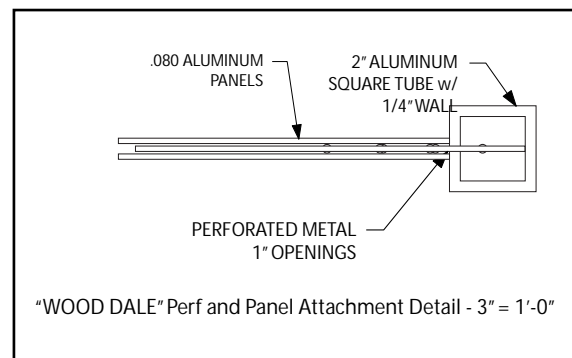

"WOOD DALE" Perf and Panel Attachment Detail - 3" = 1'-0"

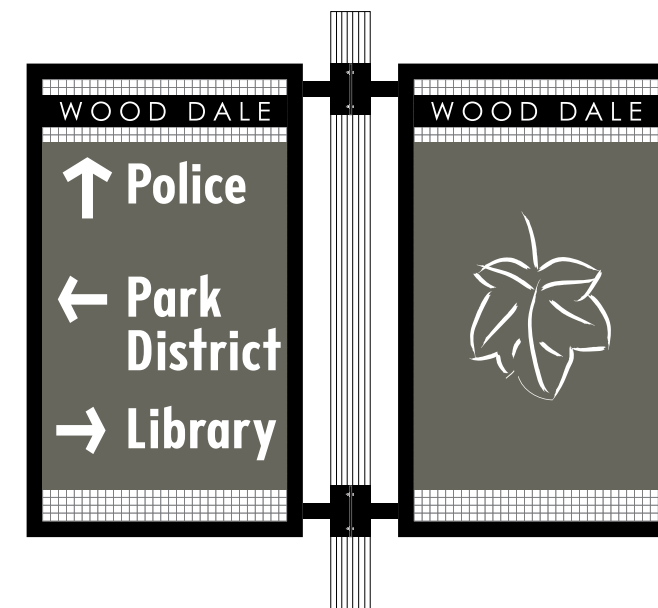

Back View - N.T.S.

By signing the **Customer Acceptance** on this print, I understand that I am accepting all aspects of this drawing. This includes Artwork, Specifications, Dimensions, Spelling, and all other representations herein. I also understand that color reproductions on this print are approximate, and may not match manufactures samples exactly.

X
Customer Acceptance SIGNATURE DATE

X
IF REQUIRED: Landlord Acceptance SIGNATURE DATE

L.S.G SALES INITIALS DATE

Landmark Sign group

www.landmarksign.com

7424 Industrial Avenue
Chesterton, IN 46304

office 219.762.9577
direct 574.252.9247

PRINT #
KB-26449-6C

KEITH BERINGER, JR.
LSG SALES REPRESENTATIVE

01.31.2022
DATE

CITY OF WOOD DALE
CLIENT NAME

WOOD DALE, IL
JOB LOCATION

LS AS NOTED
DRAWN BY SCALE

REVISIONS:

1.

RW-22572-1/15
SE-24203-1/17

UL SAFETY-US
E509514

Designed for 110/277 Volts

Electrical Connection will be Visible within 5 Ft. at time of Installation; Second Trip will be Charged at Time & Material

© 2022 LANDMARK SIGN PARTNERS LLC. This drawing is the property of Landmark Sign Partners LLC. No reproductions or exhibitions are permitted without the express written consent of Landmark Sign Partners LLC. An assessment of up to \$2500.00 will be charged for any drawing.

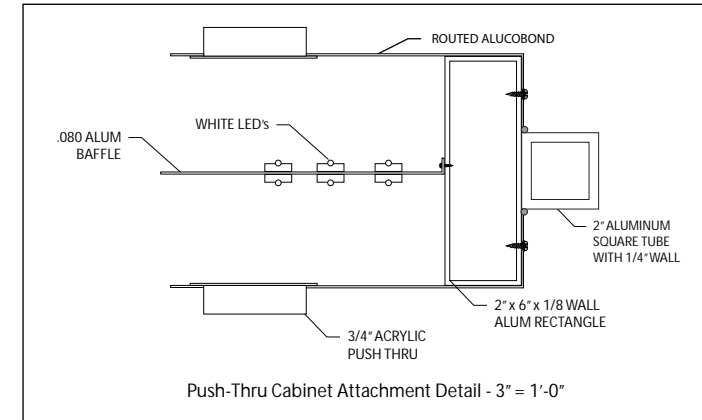
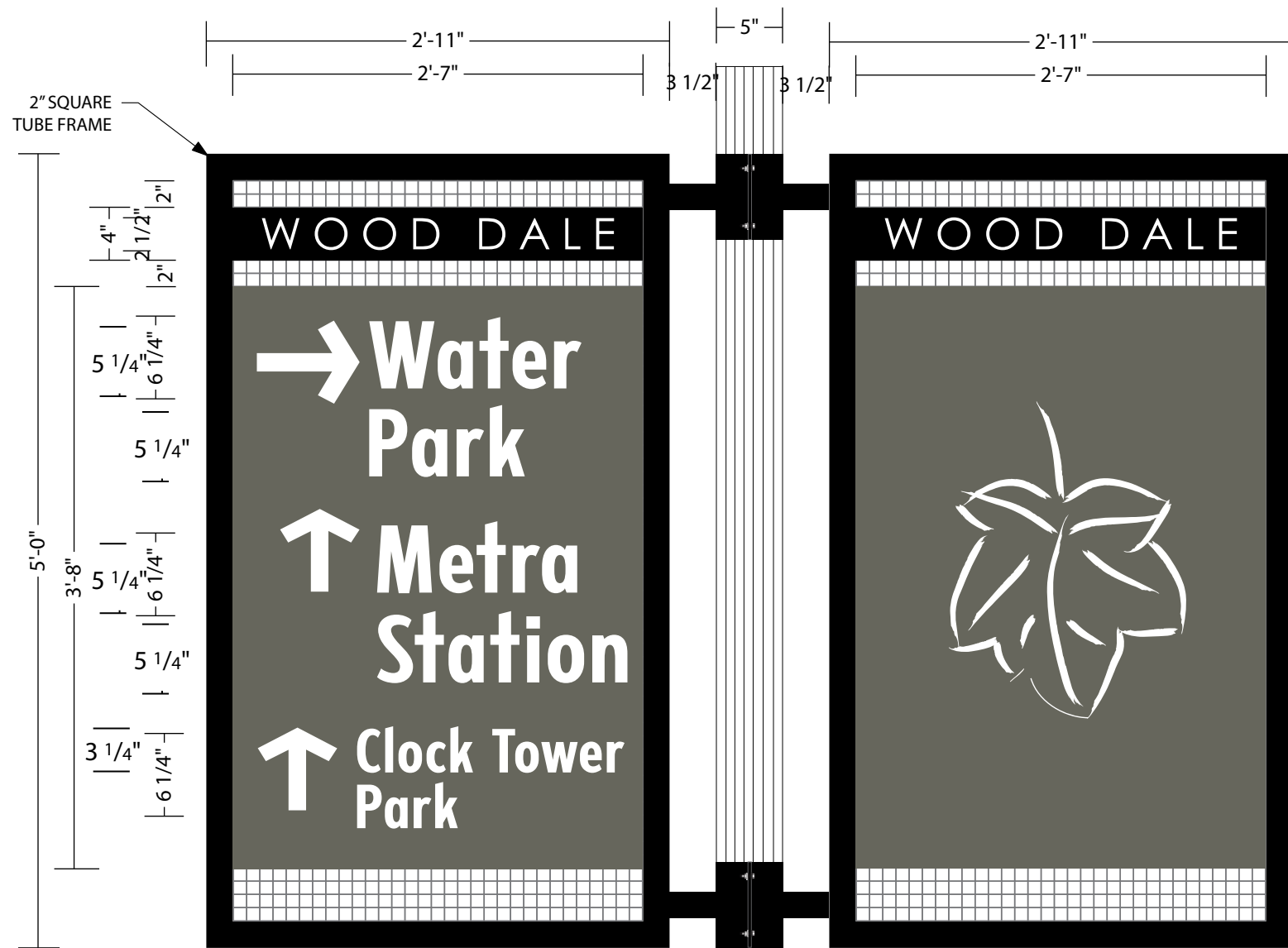

- ▶ **TWO (2) DOUBLE FACE NON ILLUMINATED .080 ALUMINUM PANELS MOUNTED TO 2" ALUMINUM TUBE FRAME with PERFORATED METAL ATTACHED TO EXISTING POLE with CUSTOM BRACKETS**
- **TUBE FRAME / MOUNTING BRACKETS= PAINTED SATIN MAP BLACK**
PERFORATED METAL = STAINLESS
TOP PANEL BKGD = PAINTED SATIN MAP BLACK
BOTTOM PANEL BKGD = PAINTED SATIN MAP MP10206 LEAD PIPE
LOGO / COPY = 7725-010 WHITE OPAQUE VINYL

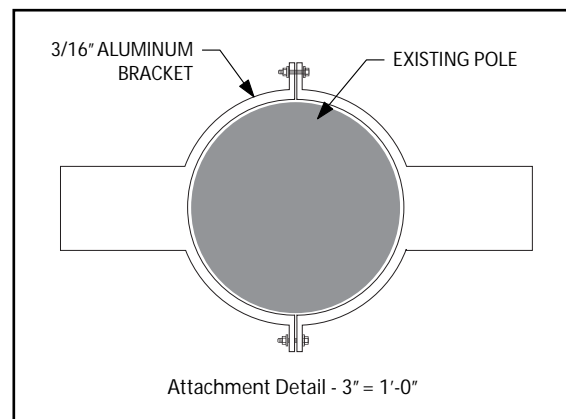

Front View 1" = 1'-0"

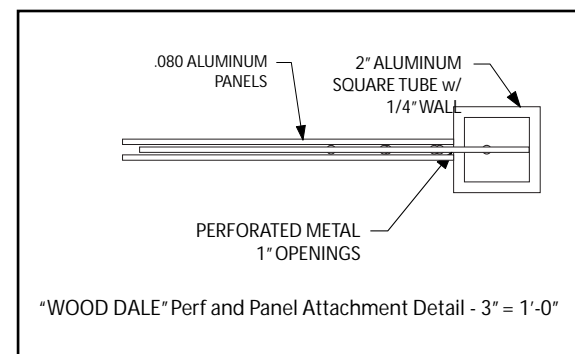

Back View - N.T.S.

By signing the **Customer Acceptance** on this print, I understand that I am accepting all aspects of this drawing. This includes Artwork, Specifications, Dimensions, Spelling, and all other representations herein. I also understand that color reproductions on this print are approximate, and may not match manufactures samples exactly.

X
Customer Acceptance SIGNATURE DATE

X
 IF REQUIRED: **Landlord Acceptance SIGNATURE** DATE

L.S.G SALES INITIALS DATE

Landmark Sign group
 www.landmarksign.com

7424 Industrial Avenue
 Chesterton, IN 46304
 office 219.762.9577
 direct 574.252.9247

PRINT #
KB-26449-6D

KEITH BERINGER, JR.
 LSG SALES REPRESENTATIVE

01.31.2022
 DATE

CITY OF WOOD DALE
 CLIENT NAME

WOOD DALE, IL
 JOB LOCATION

LS **AS NOTED**
 DRAWN BY SCALE

REVISIONS:
 1.

RW-22572-1/15
SE-24203-1/17

UL SAFETY-US
E509514

Designed for 110/277 Volts
 Electrical Connection will be Visible within 5 Ft. at time of Installation; Second Trip will be Charged at Time & Material

© 2022 LANDMARK SIGN PARTNERS LLC.
 This drawing is the property of Landmark Sign Partners LLC. No reproductions or exhibitions are permitted without the express written consent of Landmark Sign Partners LLC. An assessment of up to \$2500.00 will be charged for any drawing.

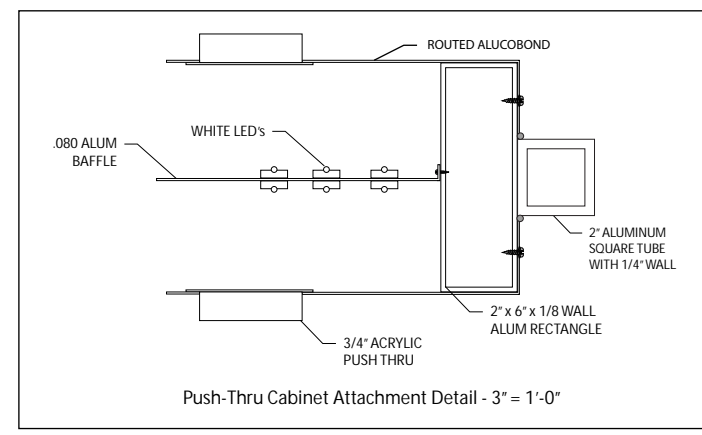

- ▶ **TWO (2) DOUBLE FACE NON ILLUMINATED .080 ALUMINUM PANELS MOUNTED TO 2" ALUMINUM TUBE FRAME with PERFORATED METAL ATTACHED TO EXISTING POLE with CUSTOM BRACKETS**
- **TUBE FRAME / MOUNTING BRACKETS= PAINTED SATIN MAP BLACK**
PERFORATED METAL = STAINLESS
TOP PANEL BKGD = PAINTED SATIN MAP BLACK
BOTTOM PANEL BKGD = PAINTED SATIN MAP MP10206 LEAD PIPE
LOGO / COPY = 7725-010 WHITE OPAQUE VINYL

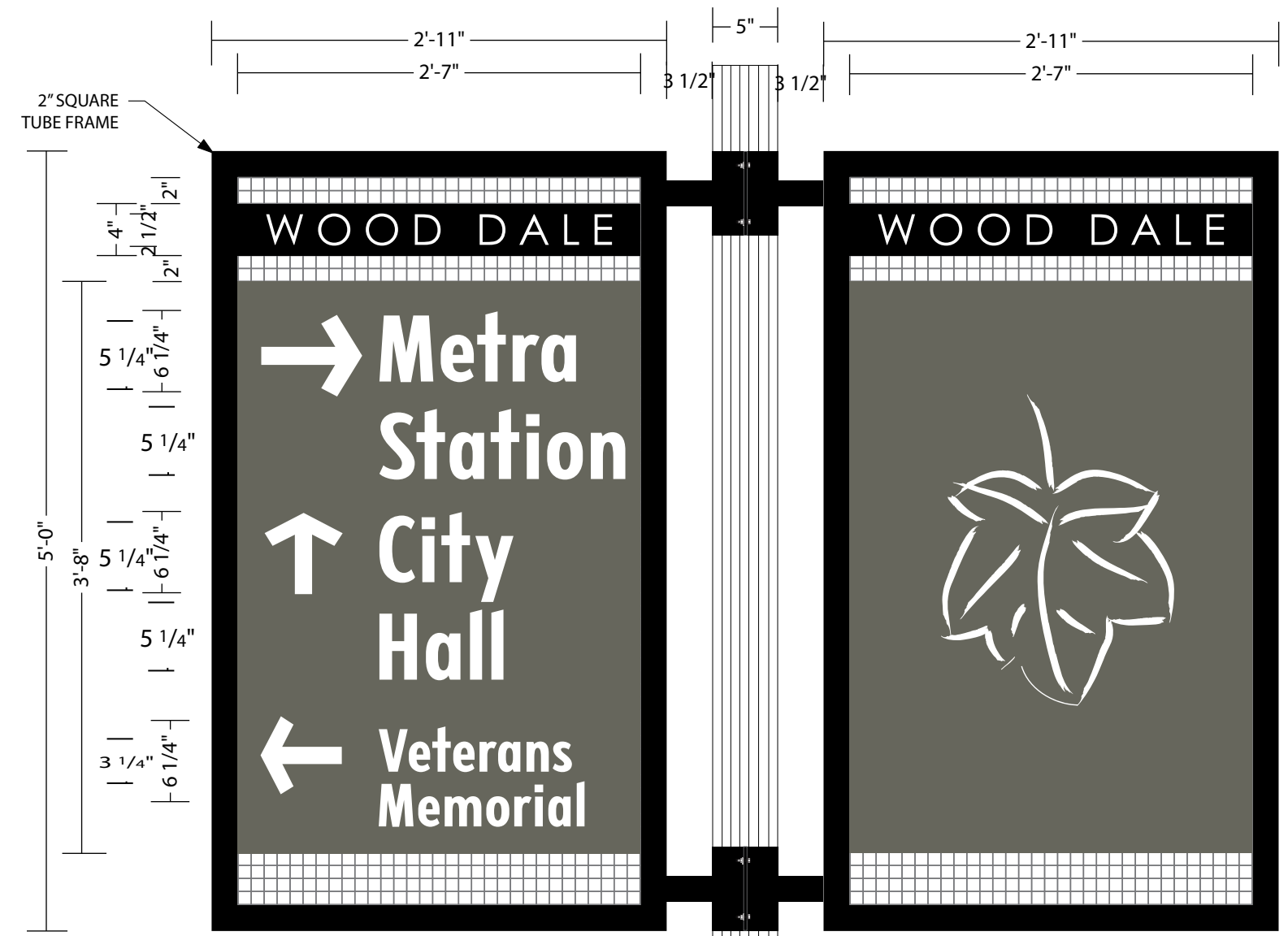

Front View 1" = 1'-0"

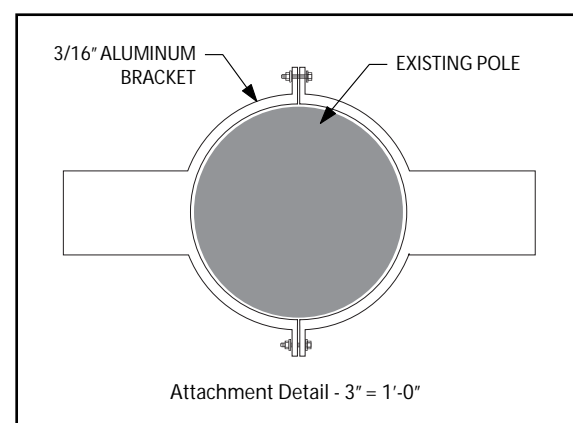

Attachment Detail - 3" = 1'-0"

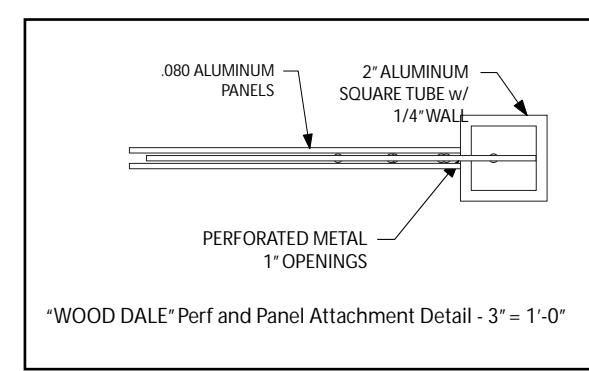

"WOOD DALE" Perf and Panel Attachment Detail - 3" = 1'-0"



Back View - N.T.S.

By signing the **Customer Acceptance** on this print, I understand that I am accepting all aspects of this drawing. This includes Artwork, Specifications, Dimensions, Spelling, and all other representations herein. I also understand that color reproductions on this print are approximate, and may not match manufactures samples exactly.

X
Customer Acceptance SIGNATURE DATE

X
 IF REQUIRED: **Landlord Acceptance SIGNATURE** DATE

L.S.G SALES INITIALS DATE

Landmark Sign group

www.landmarksign.com

7424 Industrial Avenue
 Chesterton, IN 46304

office 219.762.9577
 direct 574.252.9247

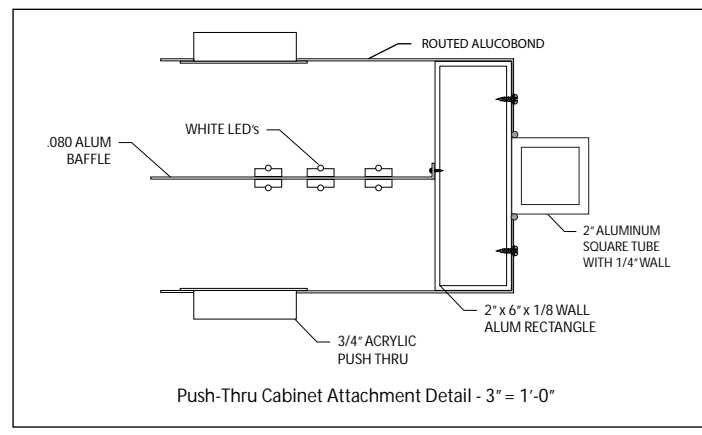
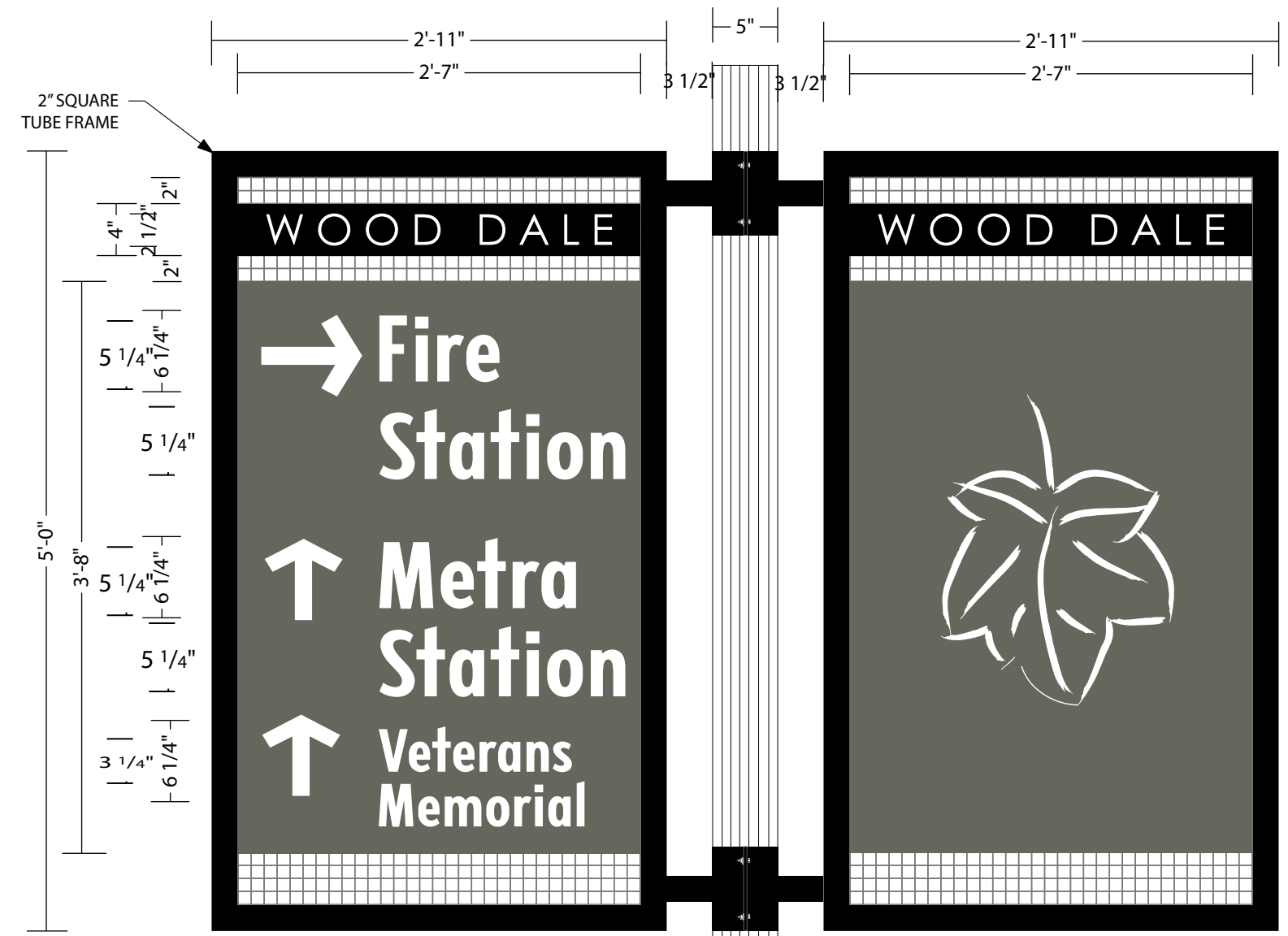

- ▶ **TWO (2) DOUBLE FACE NON ILLUMINATED .080 ALUMINUM PANELS MOUNTED TO 2" ALUMINUM TUBE FRAME with PERFORATED METAL ATTACHED TO EXISTING POLE with CUSTOM BRACKETS**
- **TUBE FRAME / MOUNTING BRACKETS= PAINTED SATIN MAP BLACK**
PERFORATED METAL = STAINLESS
TOP PANEL BKGD = PAINTED SATIN MAP BLACK
BOTTOM PANEL BKGD = PAINTED SATIN MAP MP10206 LEAD PIPE
LOGO / COPY = 7725-010 WHITE OPAQUE VINYL

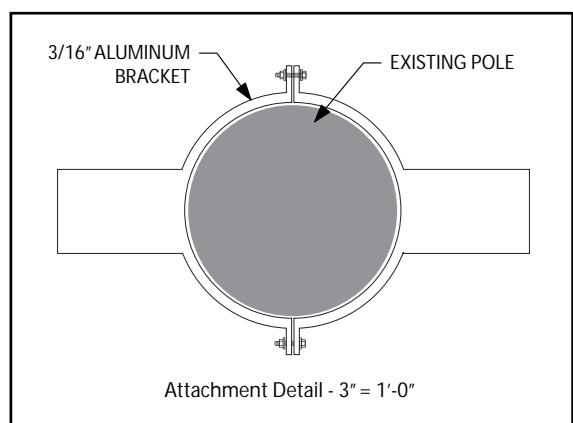

Front View 1" = 1'-0"

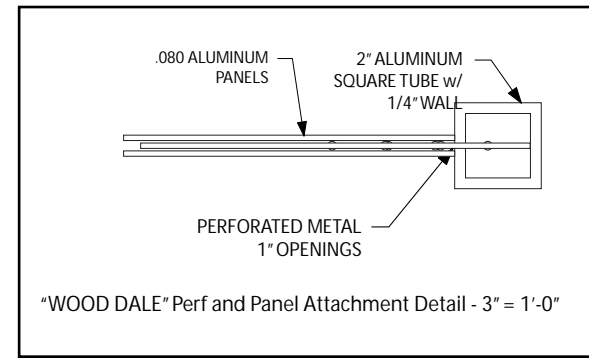

Back View - N.T.S.

PRINT #
KB-26449-6E

KEITH BERINGER, JR.
 LSG SALES REPRESENTATIVE

01.31.2022
 DATE

CITY OF WOOD DALE
 CLIENT NAME

WOOD DALE, IL
 JOB LOCATION

LS AS NOTED
 DRAWN BY SCALE

REVISIONS:

-

RW-22572-1/15
SE-24203-1/17



Designed for 110/277 Volts
 Electrical Connection will be Visible within 5 Ft. at time of Installation; Second Trip will be Charged at Time & Material

© 2022 LANDMARK SIGN PARTNERS LLC. This drawing is the property of Landmark Sign Partners LLC. No reproductions or exhibitions are permitted without the express written consent of Landmark Sign Partners LLC. An assessment of up to \$2500.00 will be charged for this drawing.

By signing the **Customer Acceptance** on this print, I understand that I am accepting all aspects of this drawing. This includes Artwork, Specifications, Dimensions, Spelling, and all other representations herein. I also understand that color reproductions on this print are approximate, and may not match manufactures samples exactly.

X
Customer Acceptance SIGNATURE DATE

X
IF REQUIRED: Landlord Acceptance SIGNATURE DATE

L.S.G SALES INITIALS DATE

Landmark Sign group

www.landmarksign.com

7424 Industrial Avenue
Chesterton, IN 46304

office 219.762.9577
direct 574.252.9247

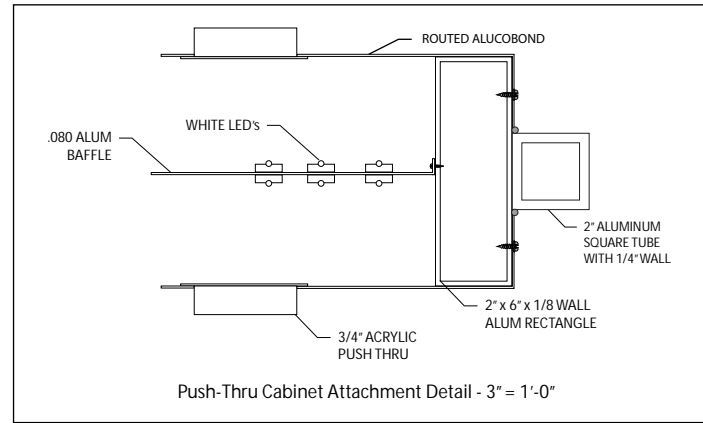
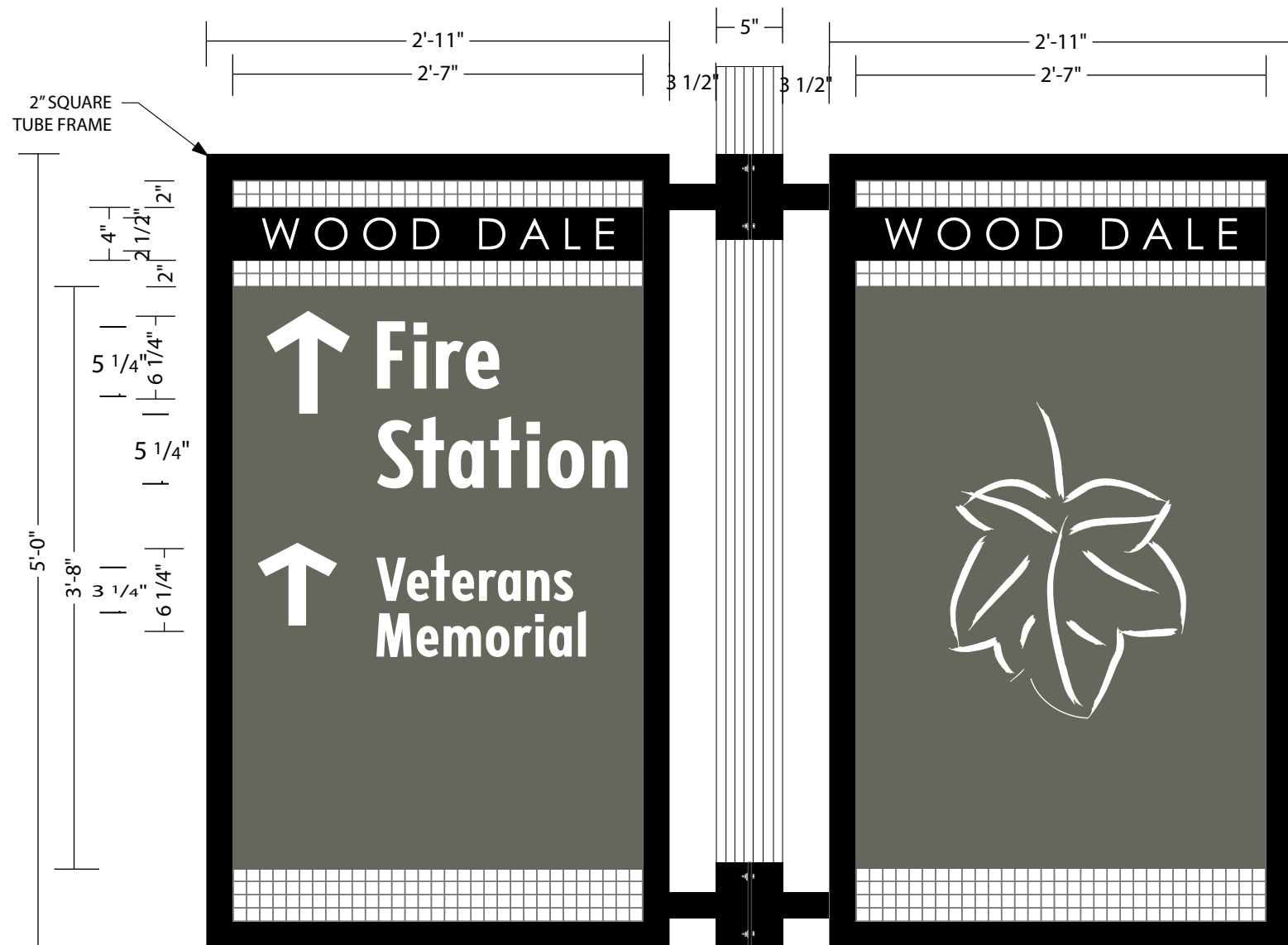

- ▶ **TWO (2) DOUBLE FACE NON ILLUMINATED .080 ALUMINUM PANELS MOUNTED TO 2" ALUMINUM TUBE FRAME with PERFORATED METAL ATTACHED TO EXISTING POLE with CUSTOM BRACKETS**
- **TUBE FRAME / MOUNTING BRACKETS= PAINTED SATIN MAP BLACK**
- **PERFORATED METAL = STAINLESS**
- **TOP PANEL BKGD = PAINTED SATIN MAP BLACK**
- **BOTTOM PANEL BKGD = PAINTED SATIN MAP MP10206 LEAD PIPE**
- **LOGO / COPY = 7725-010 WHITE OPAQUE VINYL**

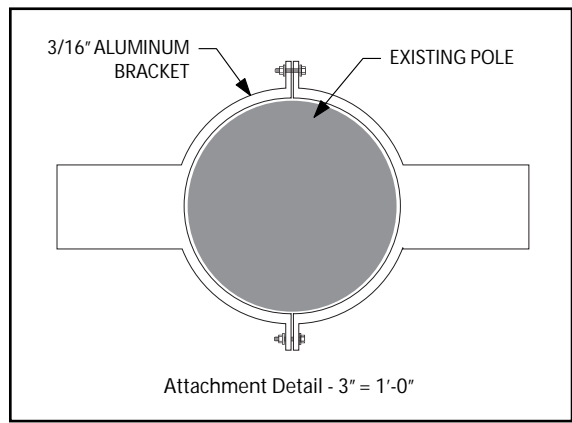

Front View 1" = 1'-0"

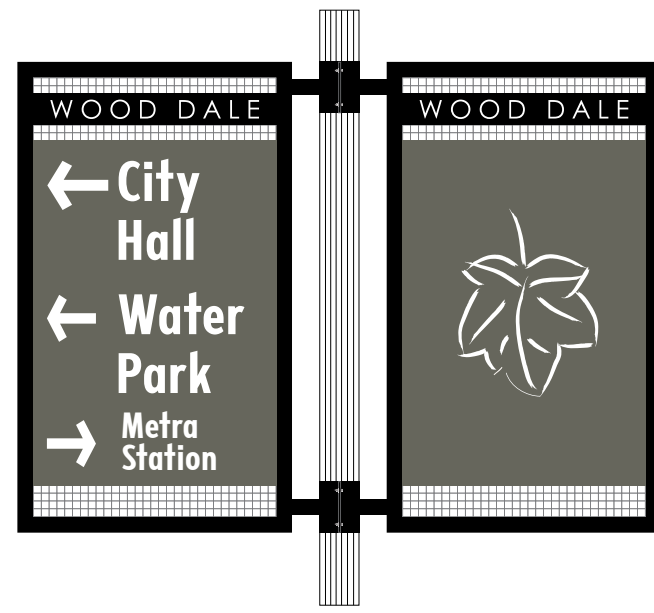
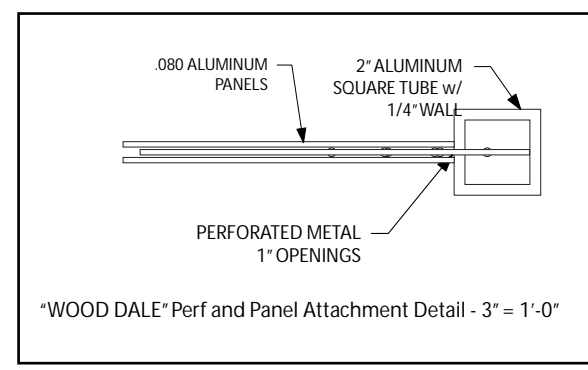

Back View - N.T.S.

PRINT #
KB-26449-6F

KEITH BERINGER, JR.
LSG SALES REPRESENTATIVE

01.31.2022
DATE

CITY OF WOOD DALE
CLIENT NAME

WOOD DALE, IL
JOB LOCATION

LS AS NOTED
DRAWN BY SCALE

REVISIONS:

-

RW-22572-1/15
SE-24203-1/17



Designed for 110/277 Volts
Electrical Connection will be Visible within 5 Ft. at time of Installation; Second Trip will be Charged at Time & Material

© 2022 LANDMARK SIGN PARTNERS LLC. This drawing is the property of Landmark Sign Partners LLC. No reproductions or exhibitions are permitted without the express written consent of Landmark Sign Partners LLC. An assessment of up to \$2500.00 will be charged for any drawing.

By signing the **Customer Acceptance** on this print, I understand that I am accepting all aspects of this drawing. This includes Artwork, Specifications, Dimensions, Spelling, and all other representations herein. I also understand that color reproductions on this print are approximate, and may not match manufactures samples exactly.

X
Customer Acceptance SIGNATURE DATE

X
 IF REQUIRED: **Landlord Acceptance SIGNATURE** DATE

L.S.G SALES INITIALS DATE

Landmark Sign group

www.landmarksign.com

7424 Industrial Avenue
 Chesterton, IN 46304

office 219.762.9577
 direct 574.252.9247

PRINT #
KB-26449-6G

KEITH BERINGER, JR.
 LSG SALES REPRESENTATIVE

01.31.2022
 DATE

CITY OF WOOD DALE
 CLIENT NAME

WOOD DALE, IL
 JOB LOCATION

LS AS NOTED
 DRAWN BY SCALE

REVISIONS:
 1.

RW-22572-1/15
SE-24203-1/17

UL SAFETY-US
 E509514

Designed for 110/277 Volts

Electrical Connection will be Visible within 5 Ft. at time of Installation; Second Trip will be Charged at Time & Material

© 2022 LANDMARK SIGN PARTNERS LLC. This drawing is the property of Landmark Sign Partners LLC. No reproductions or exhibitions are permitted without the express written consent of Landmark Sign Partners LLC. An assessment of up to \$2500.00 will be charged for any drawing.

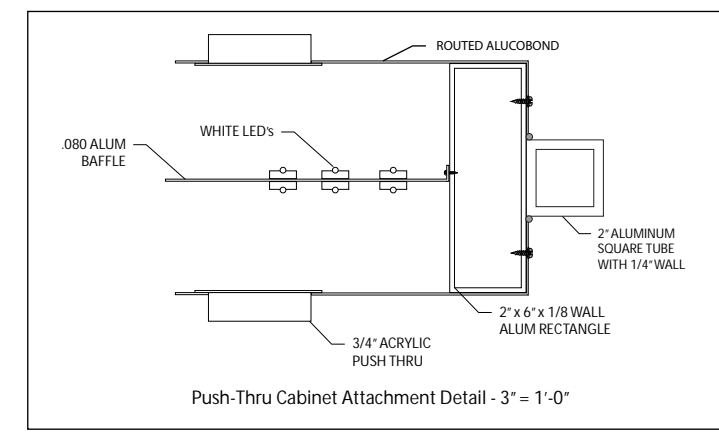

- ▶ **TWO (2) DOUBLE FACE NON ILLUMINATED .080 ALUMINUM PANELS MOUNTED TO 2" ALUMINUM TUBE FRAME with PERFORATED METAL ATTACHED TO EXISTING POLE with CUSTOM BRACKETS**
- **TUBE FRAME / MOUNTING BRACKETS= PAINTED SATIN MAP BLACK**
PERFORATED METAL = STAINLESS
TOP PANEL BKGD = PAINTED SATIN MAP BLACK
BOTTOM PANEL BKGD = PAINTED SATIN MAP MP10206 LEAD PIPE
LOGO / COPY = 7725-010 WHITE OPAQUE VINYL

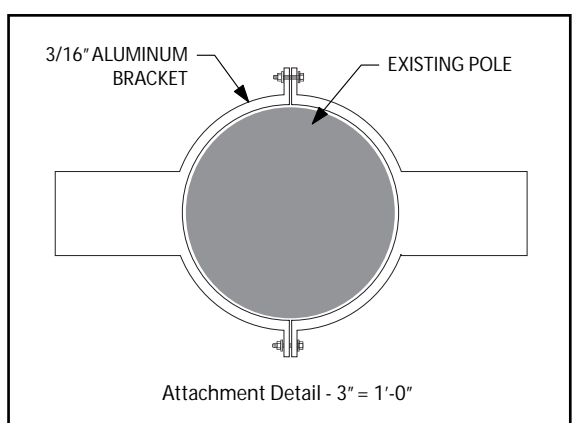
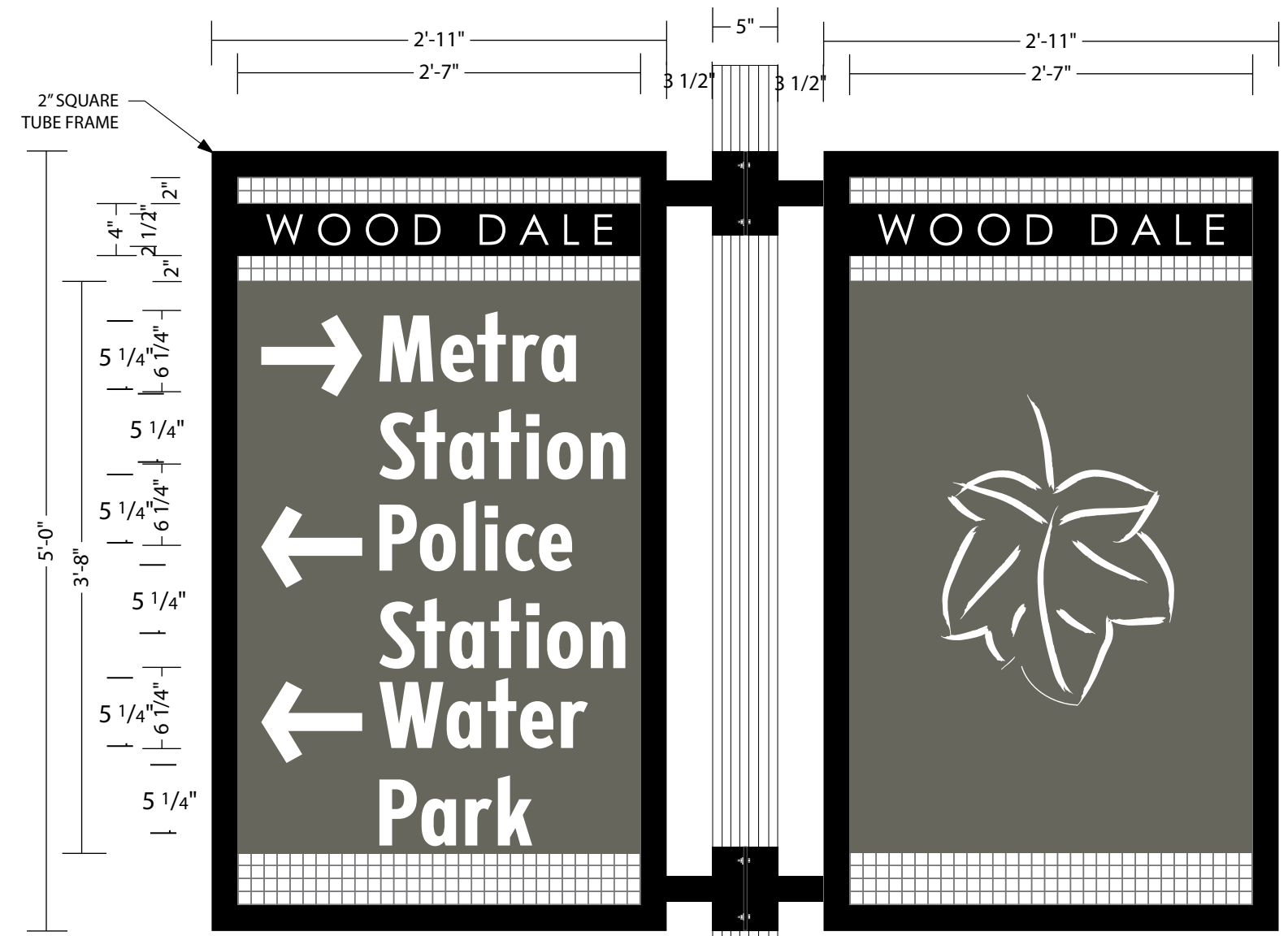

Front View 1" = 1'-0"

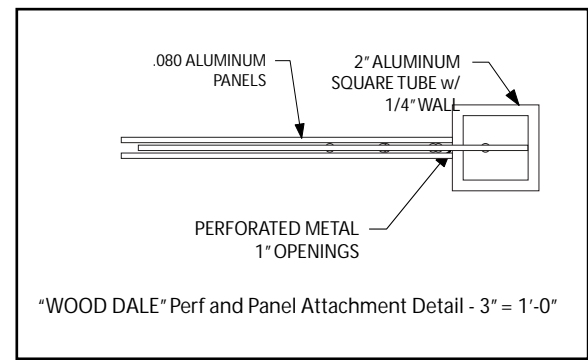

"WOOD DALE" Perf and Panel Attachment Detail - 3" = 1'-0"



Back View - N.T.S.



Purchase Agreement

Salesperson Keith Beringer
 Contract # 1
 Date Wednesday, September 14, 2022

AGREEMENTS MADE BETWEEN LANDMARK SIGN PARTNERS, LLC. HEREIN CALLED SELLER, AND BUYER:

| | | | |
|-------------------------|---|---------|-----------------------------|
| Name of Firm | <u>City of Wood Dale</u> | Contact | <u>Wilvert Ibares</u> |
| Billing Address | <u>404 N Wood Dale Rd Wood Dale, IL 60191</u> | Phone | <u>630-787-3716</u> |
| Name of Display | <u>City of Wood Dale</u> | Contact | <u>Wilvert Ibares</u> |
| Address of Installation | <u>8 separate locations around town</u> | Phone | <u>630-787-3716</u> |
| | | Email | <u>wibares@wooddale.com</u> |

1. SALE: Seller shall, to buyer's special order and specifically for Buyer's use construct for and sell to Buyer, and Buyer shall purchase from Seller, the advertising display (s) herein called, "display", in accordance with the terms of this AGREEMENT. At the option of the parties, a design approved and initialed by the parties may be attached hereto in lieu of, or to supplement the specifications set forth herein below.

5. PRICE AND TERMS:

| | | |
|----|---------------------------------------|-------------|
| a) | Price of display (s) | \$33,790.00 |
| b) | Sales or Use Tax | \$0.00 |
| c) | Subtotal | \$33,790.00 |
| d) | Less Down Payment (rec'd 50%) | \$16,895.00 |
| e) | Subtotal | \$16,895.00 |
| f) | Sign Permits (at actual cost) | |
| g) | Permit Handling Fee | \$300.00 |
| h) | Balance due upon installation (e,f,g) | \$17,195.00 |

2. SPECIFICATIONS Design # KB-26449
 Number of displays: 8

| | |
|---|-------------|
| * KB-26449 * Eight (8) sets of Two (2) double face non-illuminated .080 aluminum panels mounted to 2" aluminum tube frame with perforated metal attached to existing pole with custom brackets. Scheduled to be a two (2) full days of installation. Installation included in this pricing. | \$35,550.00 |
| 5% discount for ordering multiple like signs at once: | -\$1,760.00 |

*Applicable taxes payable under the laws of the state of installation not set forth herein are additional to the quoted price, unless paid directly by the Buyer.

**Permit Costs cannot be predetermined

All unpaid balances shall bear interest at the rate of (1 1/2%) one and one-half percent per month after thirty (30) days from the date of installation

Buyer: _____
 BY: _____
 Title: _____ Date: _____
 (Please Print Name)
 TELEPHONE NUMBER: _____

** 3.5% Discount of total balance if paid in full up front **

** 2% Discount of balance if paid in full within 10 days of completion/install (2/10 net terms) **

| | |
|----------------------------------|-------------|
| Survey Cost | |
| Installation Cost | |
| Total for signs and installation | \$33,790.00 |

**All Credit card transactions will be subject to a 3% Convenience fee / Make checks payable to Landmark Sign Partners, LLC

3. FOR ALL INSTALLATIONS, BUYER SHALL PROVIDE ELECTRICAL SERVICE OF SUITABLE CAPACITY AND APPROVED TYPE WITHIN 5 FEET OF DISPLAY (S) LOCATION IN ADVANCE OF INSTALLATION DATE. PLEASE SEE ITEM 18 SECTION (b,c,d) UNDER ADDITIONAL TERMS AND PROVISIONS

4. ACCEPTANCE OF AGREEMENT: This agreement shall not take effect until signed on behalf of Buyer and by an officer of seller. Customer acknowledges receipt of a copy of this agreement and waives notification of acceptance hereof by Landmark, THIS AGREEMENT, INCLUDING PARAGRAPHS (7) THROUGH (20) APPEARING ON THE BACK OF THIS PAGE CONSTITUTES THE ENTIRE UNDERSTANDING BETWEEN THE PARTIES. No modifications of this Agreement shall be binding on Seller unless approved in writing by an OFFICER of Seller. The parties acknowledge that they have carefully read the entire Agreement and fully understand their respective covenants hereunder. This agreement is made of specifically constructed equipment and when accepted by Buyer and Seller is not subject to cancellation.

6. UNCONDITIONAL AND ABSOLUTE PERSONAL GUARANTY: WHEREAS. LANDMARK SIGN PARTNERS, LLC. hereinafter referred to as SELLER is negotiating with _____, hereinafter referred to as BUYER, to enter into a purchase agreement for the construction and sale of certain property. and, WHEREAS, to induce SELLER to enter into said contract, _____, hereinafter referred to as GUARANTOR, wishes to guaranty any such contract(s) NOW THEREFORE.

a. Guarantor hereby absolutely and unconditionally personally guarantees the prompt payment and performance, when due, of any and every installment and obligation under any contract of contracts entered between the Seller and Buyer. b. This guarantee shall include, but not limited to, any and all sums, late charges, disbursements, costs, expenses, legal fees, and any deficiency upon enforcement of collateral which is due and owing to assignee.

c. Guarantor consents that without notice to or further assent by guarantor the obligation of Buyer under any contract hereby guaranteed may be renewed, extended, modified, premature, released, settled or compromised by Seller in liquidation, adjustment on bankruptcy or receivership proceeding or like, as it may deem advisable and that any security for said indebtedness which Seller may hold be exchanged, sold, released, or surrendered by it as may deem advisable without impairing or affecting the obligation of the guarantor hereunder.

d. Guarantor waives any and all notice of the acceptance of this guaranty, or of the creation, renewal, or accrual of any obligations or liabilities of Buyer, present of future, any and every obligation or liability of Buyer to Seller herein described shall conclusively be presumed to be in reliance upon this guaranty. Guarantor waives protest, presentment, demand for payment notice of default or non-payment and notice of dishonor to or upon Grantor, Buyer or any other party liable for Buyer's obligations hereby guaranteed. e. Seller is hereby empowered or authorized upon the occurrence of any of the following events by Buyer or Guarantor to accelerate or declare a default hereunder the balance due without notice or demand on any obligation of Buyer or Guarantor: (1) Default in payment or performance of any and all obligations guaranteed in this guaranty agreement, (2) A petition in bankruptcy being filed, (3) State receivership on assignment for benefit of creditors being filed, (4) Judgement is obtained or writ of attachment being issued, (5) Change of financial or business condition that in the opinion of the Seller will materially impair its security or increase its risk.

f. This guaranty is assignable by the Seller and in the event that the contract between the Seller and Buyer is assigned by the Seller the

Accepted: LANDMARK SIGN PARTNERS, LLC.

obligation of the Guarantor under this guaranty agreement shall inure to the benefit of any such assignee

BY: _____ BY: _____ Guarantor

TITLE: _____ DATE: _____ BY: _____ Guarantor



Purchase Agreement

Salesperson Keith Beringer
 Contract # 1
 Date Tuesday, August 9, 2022

AGREEMENTS MADE BETWEEN LANDMARK SIGN PARTNERS, LLC. HEREIN CALLED SELLER, AND BUYER:

| | | | |
|-------------------------|--|---------|----------------------------|
| Name of Firm | <u>City of Wood Dale</u> | Contact | <u>Alan Lange</u> |
| Billing Address | <u>404 N Wood Dale Rd Wood Dale, IL 60191</u> | Phone | <u>630-787-3961</u> |
| Name of Display | <u>City of Wood Dale</u> | Contact | <u>Alan Lange</u> |
| Address of Installation | <u>405 E Irvington Park Rd Wood Dale, IL 60191</u> | Phone | <u>630-768-9927</u> |
| | | Email | <u>alange@wooddale.com</u> |

1. SALE: Seller shall, to buyer's special order and specifically for Buyer's use construct for and sell to Buyer, and Buyer shall purchase from Seller, the advertising display (s) herein called, "display", in accordance with the terms of this AGREEMENT. At the option of the parties, a design approved and initialed by the parties may be attached hereto in lieu of, or to supplement the specifications set forth herein below.

5. PRICE AND TERMS:

| | | |
|----|---------------------------------------|-------------|
| a) | Price of display (s) | \$16,631.00 |
| b) | Sales or Use Tax | \$840.42 |
| c) | Subtotal | \$17,471.42 |
| d) | Less Down Payment (rec'd 50%) | \$8,735.71 |
| e) | Subtotal | \$8,735.71 |
| f) | Sign Permits (at actual cost) | |
| g) | Permit Handling Fee | \$300.00 |
| h) | Balance due upon installation (e,f,g) | \$9,035.71 |

2. SPECIFICATIONS Design # KB-26449
 Number of displays: 1

* KB-26449-7 * One (1) double face illuminated routed shobox face sign can with perforated metal and aluminum tube frame \$13,446.75

*Applicable taxes payable under the laws of the state of installation not set forth herein are additional to the quoted price, unless paid directly by the Buyer.

**Permit Costs cannot be predetermined

All unpaid balances shall bear interest at the rate of (1 1/2%) one and one-half percent per month after thirty (30) days from the date of installation

Buyer: _____
 BY: _____
 Title: _____ Date: _____
 (Please Print Name)
 TELEPHONE NUMBER: _____

** 3.5% Discount of total balance if paid in full up front **

** 2% Discount of total if paid in full within 10 days of completion/install (2/10 net terms) **

| | |
|----------------------------------|-------------|
| Survey Cost | \$516.25 |
| Installation Cost | \$2,668.00 |
| Total for signs and installation | \$16,631.00 |

**All Credit card transactions will be subject to a 3% Convenience fee / Make checks payable to Landmark Sign Partners, LLC

3. FOR ALL INSTALLATIONS, BUYER SHALL PROVIDE ELECTRICAL SERVICE OF SUITABLE CAPACITY AND APPROVED TYPE WITHIN 5 FEET OF DISPLAY (S) LOCATION IN ADVANCE OF INSTALLATION DATE. PLEASE SEE ITEM 18 SECTION (b,c,d) UNDER ADDITIONAL TERMS AND PROVISIONS

4. ACCEPTANCE OF AGREEMENT: This agreement shall not take effect until signed on behalf of Buyer and by an officer of seller. Customer acknowledges receipt of a copy of this agreement and waives notification of acceptance hereof by Landmark, THIS AGREEMENT, INCLUDING PARAGRAPHS (7) THROUGH (20) APPEARING ON THE BACK OF THIS PAGE CONSTITUTES THE ENTIRE UNDERSTANDING BETWEEN THE PARTIES. No modifications of this Agreement shall be binding on Seller unless approved in writing by an OFFICER of Seller. The parties acknowledge that they have carefully read the entire Agreement and fully understand their respective covenants hereunder. This agreement is made of specifically constructed equipment and when accepted by Buyer and Seller is not subject to cancellation.

6. UNCONDITIONAL AND ABSOLUTE PERSONAL GUARANTY: WHEREAS, LANDMARK SIGN PARTNERS, LLC. hereinafter referred to as SELLER is negotiating with _____, hereinafter referred to as BUYER, to enter into a purchase agreement for the construction and sale of certain property. and, WHEREAS, to induce SELLER to enter into said contract, _____, hereinafter referred to as GUARANTOR, wishes to guaranty any such contract(s) NOW THEREFORE.

a. Guarantor hereby absolutely and unconditionally personally guarantees the prompt payment and performance, when due, of any and every installment and obligation under any contract of contracts entered between the Seller and Buyer. b. This guarantee shall include, but not limited to, any and all sums, late charges, disbursements, costs, expenses, legal fees, and any deficiency upon enforcement of collateral which is due and owing to assignee.

c. Guarantor consents that without notice to or further assent by guarantor the obligation of Buyer under any contract hereby guaranteed may be renewed, extended, modified, premature, released, settled or compromised by Seller in liquidation, adjustment on bankruptcy or receivership proceeding or like, as it may deem advisable and that any security for said indebtedness which Seller may hold be exchanged, sold, released, or surrendered by it as may deem advisable without impairing or affecting the obligation of the guarantor hereunder.

d. Guarantor waives any and all notice of the acceptance of this guaranty, or of the creation, renewal, or accrual of any obligations or liabilities of Buyer, present of future, any and every obligation or liability of Buyer to Seller herein described shall conclusively be presumed to be in reliance upon this guarantee. Guarantor waives protest, presentment, demand for payment notice of default or non-payment and notice of dishonor to or upon Grantor, Buyer or any other party liable for Buyer's obligations hereby guaranteed.

e. Seller is hereby empowered or authorized upon the occurrence of any of the following events by Buyer or Guarantor to accelerate or declare a default hereunder the balance due without notice or demand on any obligation of Buyer or Guarantor: (1) Default in payment or performance of any and all obligations guaranteed in this guaranty agreement, (2) A petition in bankruptcy being filed, (3) State receivership on assignment for benefit of creditors being filed, (4) Judgement is obtained or writ of attachment being issued, (5) Change of financial or business condition that in the opinion of the Seller will materially impair its security or increase its risk.

f. This guaranty is assignable by the Seller and in the event that the contract between the Seller and Buyer is assigned by the Seller the

Accepted: LANDMARK SIGN PARTNERS, LLC.

obligation of the Guarantor under this guaranty agreement shall inure to the benefit of any such assignee

BY: _____ BY: _____ Guarantor

TITLE: _____ DATE: _____ BY: _____ Guarantor



REQUEST FOR COMMITTEE ACTION

Referred to Committee: September 22, 2022
Subject: Public Works Fuel Tank Replacement
Staff Contact: Alan Lange, Public Works Director
Department: Public Works

TITLE: Approval of an Agreement between the City of Wood Dale and Crowne Industries, Ltd. for the Public Works Fuel Tank Replacement Project in an Amount Not to Exceed \$27,969

RECOMMENDATION:

Staff Recommends Approval of an Agreement between the City of Wood Dale and Crowne Tank Ltd. for the Public Works Facility Fuel Replacement Project in an Amount Not to Exceed \$27,969.00.

BACKGROUND:

The City is currently undertaking the Public Works Facility Improvements Project. One aspect of this project is replacing one of the two fuel tanks due to its condition. The tank that is anticipated to be replaced will contain gasoline. The tank will include a new pump and gallon counting mechanism. The scope consists of delivery and installation costs. Bids were publicly advertised, and a bid opening was held on September 15, 2022. The bid was advertised in the Dailey Herald and sent to five tank installation contractors. One bid was received from Crown Industries, Ltd.

ANALYSIS:

\$75,000 was budgeted within the CIP in FY 23 for fuel tank replacement costs associated with the Public Works Facility Improvements project. While only one bid was received, staff had previously obtained general budget numbers early on in the design phase of the Public Works Facility Improvement Project and find Crown Industries, Ltd. bid submittal to be in line with anticipated costs for the completion of this work.

DOCUMENTS ATTACHED

✓ Crowne Industries, Ltd. bid package

RETURN WITH BID

Submitted By: Robert Sumoski

Company Name: Crowne Industries, Ltd.

Contact Person: Robert Sumoski

Address: 651 S Sutton Road, #214

City, State, Zip: Streamwood, IL 60107

Telephone: 630.497.9009

Fax: 630.929.7555

**CITY OF WOOD DALE
DUPAGE COUNTY, ILLINOIS**

**NOTICE TO CONTRACTORS
CONTRACT DOCUMENTS
SPECIFICATIONS**

FOR

**CITY OF WOOD DALE
Fuel Tank Replacement Project
September 6, 2022**

Annunziato Pulice, Mayor

Lynn Curiale City Clerk

Prepared By:

City of Wood Dale, Public Works
404 N. Wood Dale Road
Wood Dale, Illinois 60191

CITY OF WOOD DALE
Fuel Tank Replacement Project

NOTICE TO BIDDERS

Sealed bids for the **“Fuel Tank Replacement Project”** will be received in the office of the City Clerk, City of Wood Dale, IL 60191 until 10:30 a.m. on September 14, 2022, at which time all bids will be publicly opened and read. All bids must be submitted in a sealed envelope marked in the lower left hand corner **“SEALED BID, DO NOT OPEN; PROPOSAL OF [NAME OF BIDDER] FOR THE CITY OF WOOD DALE Fuel Tank Replacement Project.”** Specifications may be obtained at the Clerk’s office or by mail/email upon request. This is a prevailing wage project.

Please contact Patrick Hastings, Assistant Public Works Director, by phone 630.787.3765, or by email at phastings@wooddale.com, with any questions regarding the bid.

All proposals must be accompanied by a bid guarantee consisting of a bid bond, a cashier's check, or certified check in the amount of not less than ten percent (10%) of the amount of the bid.

Failure of the U.S. Post Office or any other messenger service to deliver the bid on time will not be the responsibility of the City of Wood Dale. The bidders accept full responsibility for timely delivery of their bids. The City of Wood Dale is not liable for any costs incurred in submitting a bid.

The City Council reserves the right to reject any or all bids and to waive any technicalities. The City of Wood Dale also reserves the right to delay the bid opening for a reasonable time and/or to make changes to the project’s specifications by means of bid addendum which will be mailed to all interested parties that have obtained bid documents.

Lynn Curiale,
City Clerk

Dated this 6th day of September, 2022

CITY OF WOOD DALE
Fuel Tank Replacement Project
DEFINITIONS

1. Owner - The officials, employees, and agents of the City of Wood Dale, Illinois.
2. Director - The City of Wood Dale's Director of Public Works or designee.
3. City - The geographic area of the City of Wood Dale, Illinois.
4. Contract - The agreement created by and consisting of the Contract Documents.
5. Contract Documents - The following documents including the Notice to Bidders, Definitions, General Terms and Conditions and Instructions to Bidders, Special Instructions, Proposal, Specifications, Special Provisions, Disclosure of Beneficiaries, Certifications, and attachments, together with all addenda issued prior to the award of the Contract supplementing or modifying any of those documents.
6. Contractor or General Contractor - The party contracting for the work.
7. Days - Unless otherwise stated, days as used herein will be understood to mean calendar days.
8. Completion Date - Date on which the work as described herein is to be completed, as set forth in the Contract.
9. Final Acceptance - The work shall be deemed to have been finally accepted after it has been determined that the Contractor has complied with the Specifications and other Contract Documents.
10. Specifications - Specifications identified in the Contract.
11. Subcontractor - Secondary Contractor engaged by the Contractor.
12. Supplier - Any vendor supplying materials, equipment, or apparatus.

CITY OF WOOD DALE
Fuel Tank Replacement Project

GENERAL TERMS AND CONDITIONS AND INSTRUCTIONS TO BIDDERS

THE GENERAL RULES AND CONDITIONS THAT FOLLOW APPLY TO EACH FORMAL INVITATION TO BID ISSUED BY THE CITY OF WOOD DALE, UNLESS OTHERWISE SPECIFIED. BIDDERS OR THEIR AUTHORIZED REPRESENTATIVES ARE EXPECTED TO FULLY INFORM THEMSELVES OF THE TERMS, CONDITIONS, REQUIREMENTS AND SPECIFICATIONS BEFORE SUBMITTING BIDS. FAILURE TO DO SO WILL BE AT THE BIDDER'S OWN RISK AND NO RELIEF WILL BE GRANTED OR SECURED ON A PLEA OF ERROR.

INSTRUCTIONS TO BIDDERS

1. PROPOSAL FORMS HAVE BEEN FURNISHED: Proposals shall be submitted on the forms provided, properly signed in the appropriate place and submitted in a sealed envelope.
2. LATE BIDS: Bids will opened precisely at the assigned time. Bids received after the assigned time will be rejected and returned unopened to the sender. Formal bids, amendments thereto, or requests for withdrawal of bids after the time specified for the bid opening will not be considered.
3. WITHDRAWAL OF BIDS: A written request for the withdrawal of a bid will be granted if the request is received by the City prior to the specified time of opening.
4. SUBMISSION OF BIDS: All bids are to be placed in a sealed, opaque envelope addressed to the City Clerk, City of Wood Dale, Illinois, clearly marked "**SEALED BID, DO NOT OPEN. PROPOSAL OF (NAME OF BIDDER) FOR CITY OF WOOD DALE Fuel Tank Replacement Project.**"
5. SIGNATURES: All signatures shall be in handwriting, and no proposal shall be considered unless properly signed by the bidder or its legally authorized agent or representative, with addresses given in the correct spaces provided in the Proposal and in accordance with the directions set forth.
6. ERRORS IN BIDS: When an error is made in extending total prices, the unit bid price will govern. Erasures, etc., must be initialed by the bidder prior to submission of the bid.
7. TIME FOR RECEIVING BIDS: Bids received prior to the time of opening will be kept secure and unopened. No responsibility will attach to the City Clerk or her representative for the premature opening of a bid not properly addressed or identified. The City Clerk or her representative, whose duty it is to open the bids, will decide when the specified time for opening has arrived, and no bid received after that time will be considered.

8. BIDDERS PRESENT: At the time assigned for the opening of formal bids, the bids will be opened and read aloud. Bidders are encouraged to attend all openings and to offer constructive suggestions for improvements to bid format or any way in which greater savings can be realized.
9. NO BID RESPONSE: In the event you cannot submit a bid on the Owner's requirements, please return the Proposal with an explanation as to why you are unable to bid and mark it "NO BID."
10. BIDDER INTERESTED IN MORE THAN ONE BID: Only one bid can be offered by any one vendor. A party who has quoted prices for work, materials, or supplies to a bidder is not thereby disqualified from quoting prices to other bidders or from submitting a bid directly for the work, materials, or supplies.

Unless the proposal form states that an alternate proposal is permissible, each vendor may submit only ONE proposal. If an alternate is included in the bid and it was not requested by the Owner, the first proposal seen by the Owner will be read, and the other will not be considered.

11. CERTIFICATIONS AND DISCLOSURE OF BENEFICIARIES: The Bidder is required to complete the forms listed above and return with the Bid Proposal. Failure to complete and return these forms may be considered sufficient reason for rejection of the bid.
12. BID DEPOSIT: When a bid deposit (bid guarantee) is required as indicated in the Invitation to Bid, each bid must be accompanied by a bid bond signed by a surety company authorized to do business in the State of Illinois, or by a cashier's check or certified check in an amount equal to ten percent (10%) of the total bid price or the specific amount indicated in the Invitation to Bid.
13. RETURN OF CHECKS: The bid deposit of all except the three (3) lowest responsible, responsive bidders on each contract will be returned within fifteen (15) days after the opening of bids. The remaining bid deposits of each contract will be returned within fifteen (15) days after the City Council has awarded the contract and the required appurtenances to the contract have been received.
14. ACCEPTANCE OF PROPOSALS: The owner will accept, in writing, one of the proposals within sixty (60) days from the date of opening of bids, or the time specified within the specifications, unless the lowest responsible, responsive bidder extends the time of acceptance to the Owner.
15. TAX EXEMPTION: The City of Wood Dale is exempt from Illinois Retailers Occupational Tax (Sec. IROETA); the Illinois use tax (Sec. 3, IUTA), and the federal excise tax as an exempt entity (See. 4222, IRC). The City's Tax Exemption Identification Number is E9997-4282-03.
16. PREVAILING WAGE: Under Public Works contracts, the State of Illinois requires that the general prevailing rate of wages in this locality be paid for each craft or type of work hereunder. This shall include payment of the general prevailing rate for legal holiday and overtime work. It shall be mandatory upon the subcontractor under the Contractor. If wage rates change during the course of the project, the new rates will be available in the Wood Dale City Clerk's Office. This

requirement is in accordance with Public Act 86-799.

17. CHANGE ORDER AUTHORIZATIONS: All Change Orders which authorize a net increase or decrease in the cost of the contract by \$10,000 or more or in the time of completion by 30 days or more require a written determination supporting the change, executed first by the Contractor, then by the City Council.

All Change Orders which authorize a net increase or decrease in the cost of the contract by less than \$10,000, or in the time of completion by less than 30 days, require a written determination supporting the change, executed first by the Contractor, then by the City Manager.

Requests for Change Orders must state that the circumstances said to necessitate the change were not reasonably foreseeable at the time the contract was signed and were not within the contemplation of the contract as signed.

18. EQUAL EMPLOYMENT OPPORTUNITY: In the event of the contractor's noncompliance with any provision of the Equal Employment Opportunity Act, the Americans with Disabilities Act (ADA), the Illinois Fair Employment Practices Act, or the Fair Employment Practices Commission's Rules and Regulations for Public Contracts, the contractor may be declared non-responsible and therefore ineligible for future contracts or subcontracts with the State of Illinois or any of its political subdivisions or municipal corporations, and the contract may be canceled or avoided, in whole or in part, and such other sanctions or penalties may be imposed or remedies involved as provided by statute or regulation.
19. AWARD OR REJECTION OF BIDS: The contract will be awarded to the lowest responsible, responsive bidder or any other bidder determined by the Owner to be in the best interest of the City of Wood Dale complying with all the provisions of the invitation, provided the bid price is reasonable and it is in the interest of the City to accept it. No proposal will be accepted from or contract awarded to any person, firm, or corporation that is in arrears or is in default to the City of Wood Dale upon any debt or contract, or that is a defaulter, as surety or otherwise, upon any obligation to said City of Wood Dale, or had failed to perform faithfully any previous contract with the City of Wood Dale. The Owner reserves the right to reject any or all bids and to waive any informality in bids received whenever such rejection or waiver is in the interests of the City.

In determining responsibility, the following qualifications, in addition to price, will be considered by the Owner:

- A. The ability, capacity and skill of the bidder to perform the service required within the specified time;
- B. The character, integrity, reputation, judgment, experience, and efficiency of the bidder;
- C. The quality of performance of previous contracts or services with the City of Wood Dale or other clients;

- D. The previous and existing compliance by the bidder with laws and ordinances relating to previous contracts with the City of Wood Dale, the bidder's employment practices and compliance with ADA requirements;
 - E. The sufficiency of the financial resources and ability of the bidder to perform the contract or provide the service;
 - F. The quality, availability, and adaptability of the supplies or contractual services to the particular use required;
 - G. The ability of the bidder to provide future maintenance and service for the use of the subject of the contract;
 - H. The number and scope of conditions attached to the bid; and
 - I. Such other information as may be secured by the Owner having a bearing on the decision to make the award.
20. ESTIMATED BID QUANTITIES: On "Estimated Bid Quantities," acceptance will bind the Owner to pay for, at unit bid prices, only quantities ordered and delivered. Any reference to forecasted or estimated quantities within the bidding documents is intended to inform the bidder of approximate annual requirements. The Owner may purchase as little as zero (0) percent or as much as one hundred fifty (150) percent of the forecasted or estimated quantities.
21. CONTRACTOR PAYMENTS: Contractor will be paid from funds allocated to the project. Payments will be made according to the Local Government Prompt Payment Act (50 ILCS 505).
22. GENERAL GUARANTY: Contractor agrees to save the City of Wood Dale, its agents, and employees harmless from liability of any nature or kind for the use of any copyrighted or uncopyrighted composition, secret process, patented or unpatented invention, article, or appliance furnished or used in the performance of the contract of which the Contractor is not the patentee, assignee, licensee, or owner.
- Contractor agrees to protect the City of Wood Dale against latent defective material or workmanship and to repair or replace any damages or marring occurring in transit or delivery.
- Contractor agrees to pay for all permits, licenses, and fees; and give all notices and comply with all laws, ordinances, and rules of the City of Wood Dale and State of Illinois.
23. ASSIGNMENT: Assignment of this contract or any part thereof, or any funds to be received thereunder by the contractor shall be subject to written approval of the Owner.

24. DEFAULT: The contract may be canceled or annulled by the Owner in whole or in part by written notice of default to the Contractor upon nonperformance or violation of contract terms. An award made to the next low Bidder or materials/services specified may be procured on the open market similar to those so terminated. In either event, the defaulting Contractor (or his surety) shall be liable to the City of Wood Dale for costs to the City in excess of the defaulted contract prices provided, that the Contractor shall continue the performance of this contract to the extent not terminated under the provisions of this clause. Failure of the contractor to deliver materials or services within the time stipulated in the bid, unless extended in writing by the Owner, shall constitute contract default.

25. INSURANCE: The Contractor shall procure, and maintain for the duration of the contract, insurance against claims for injuries to persons or damages to property which may arise from or in connection with the performance of the work hereunder by the Contractor, his agents, representatives, employees, or subcontractors.

A. Minimum Scope of Insurance

Policy shall include the following coverage types:

1. Commercial General Liability Occurrence form with the City of Wood Dale named as additional insured;
2. Owners and Contractors Protective Liability (OCP) policy with the City of Wood Dale named as additional insured;
3. Business Auto Liability Coverage;
4. Worker's Compensation as required by the Worker's Compensation Act of the State of Illinois and Employer's Liability insurance;
5. Builder Risk Property Coverage with City of Wood Dale as loss payee; and
6. Environmental Impairment/Pollution Liability Coverage for pollution incidents as a result of a claim for bodily injury, property damage or remediation costs from an incident at, on or migrating beyond the contracted work site. Coverage shall be extended to Non-Owned Disposal sites resulting from a pollution incident at, on or mitigating beyond the site; and also provide coverage for incidents occurring during transportation of pollutants. (Contract Specific).

B. Minimum Limits of Insurance: See attachment "A"

26. QUESTIONS OF THE BIDDER DIRECTED TO THE CITY REGARDING SPECIFICATIONS: If the question pertains to information which is provided in the specifications or the bidder is requesting a clarification of a point which is answerable within the context of the specification, the City Clerk, or designee, may refer the bidder to the

location within the specification providing the information which will readily answer the contractor's question.

If the question is a request to deviate from the terms and conditions of the specification or if the bidder needs clarification that is not apparent in the specification such as an interpretation of the drawings, specifications, or the bid documents, the bidder must make such an inquiry in writing to Patrick Hastings, Assistant Public Works Director, City of Wood Dale, 404 N. Wood Dale Road, Wood Dale, IL 60191. Phone Number: (630)787-3765. The City Clerk will then respond in writing in the form of an addendum to the specifications to all those who receive bid packages. Only inquiries received a minimum of three (3) working days prior to the date set for the opening of bids will be given any consideration. Oral answers will not be binding on the City of Wood Dale.

27. SPECIAL CONDITIONS: Whenever special conditions are written into the Specifications, Special Provisions, or Special Instructions which conflict with conditions stated in these General Terms and Conditions and Instructions to Bidders, the conditions stated in the Specifications, Special Provisions, or Special Instructions shall take precedence.

ATTACHMENT "A"
INSURANCE REQUIREMENTS

| <u>Type of Insurance</u> | <u>Limits of Liability</u> |
|--|--------------------------------|
| General Liability: | Property Damage: |
| Comprehensive Form | \$1,000,000 each occurrence |
| Premises – Operations | |
| Products/Completed Operations | |
| Hazard | |
| Contractual Insurance | |
| Broad Form Property Damage | Bodily Injury: |
| Independent Contractors | \$1,000,000 aggregate |
| Personal Injury | |
| Explosion and Collapse Hazard | |
| Underground Hazard | |
| Automobile Liability: | Bodily Injury and Property |
| Comprehensive Form | Damage Combined: |
| Owned | \$1,000,000 each occurrence |
| Hired | |
| Non-owned | |
| Excess Liability: | Bodily Injury and Property |
| Umbrella Form | Damage Combined: |
| | \$2,000,000 each occurrence |
| | \$2,000,000 aggregate |
| Worker's Compensation and Employer's Liability: | \$500,000 each accident |

The coverage afforded the additional insureds shall be primary insurance for the additional insureds with respect to claims or suits arising out of operations performed by or on behalf of the Contractor.

If the additional insureds have other insurance which is applicable to the loss, such other insurance shall be on an excess or contingent basis. The amount of the company's liability under the insurance policy shall not be reduced by the existence of such other insurance.

A. Workers' Compensation and Employers' Liability Coverages

The insurer shall agree to waive all rights of subrogation against the City of Wood Dale, its officials, agents, employees and volunteers for losses arising from work performed by Contractor for the City of Wood Dale.

B. All Coverages

Each insurance policy required by this clause shall be endorsed to state that coverage shall not be suspended, voided, cancelled, reduced in coverage or in limits except after thirty (30) days prior written notice by certified mail, return receipt requested, has been given to the City.

C. Verification of Coverage

Contractor shall furnish the City with certificates of insurance naming the member, its officials, agents, employees and volunteers as additional insureds, and with original endorsements affecting coverage required by this clause. The certificates and endorsements for each insurance policy are to be signed by a person authorized by that insurer to bind coverage on its behalf. The certificates and endorsements may be on the forms provided by the City and are to be received and approved by the City before any work commences.

D. Assumption of Liability

The contractor assumes liability for all injury or death of any person or persons including employees of the contractor, or any sub-contractor, any supplier or any other person and assumes liability for all damage to property sustained by any person or persons so occasioned by or in any way arising out of any work performed pursuant to this agreement.

E. Regulatory Requirements

Contractor bidder must comply with all applicable laws, regulations, and rules promulgated by any Federal, State, County, Municipal and/or other governmental unit or regulatory body now in effect or which may be in effect during the performance of the work. Included within the scope of the laws, regulations, and rules referred to in this paragraph but in no way to operate as a limitation, are Occupational Safety and Health Act (OSHA), Illinois Department of Labor (IDOL), Department of Transportation, all forms of traffic regulations, public utility, Intrastate and Interstate Laws, the Social Security Act of the Federal Government and any of its titles, the Illinois Department of Human Rights, Human Rights Commission, or EEOC statutory provisions and rules and regulations.

F. Contractor's Drug-Free Workplace Certification

Pursuant to Chapter 30, Section 580/1 of the Illinois compiled Statutes (30 ILCS 580/1) "Drug Free Workplace Act", the Contractor must certify to the contracting agency that it will provide a drug free workplace that will be included in the bid packet.

G. Sexual Harassment Policy Certification

The contractor, pursuant to Illinois compiled statutes 775 ILCS 5/2-105 (A) (4), must be in full compliance and have a written sexual harassment policy in place and provide a copy of such written policy to the Illinois Department of Human Rights upon request.

H. Indemnity/Hold Harmless

The Contractor hereby agrees to indemnify and defend the City of Wood Dale, its officers, agents, and employees and each of them, against and hold it and them harmless from any and all lawsuits, claims, demands, liabilities, losses and expenses, including court costs and attorneys' fees, for or on account of any injury to any person, or any death at any time resulting from such injury, or any damage to any property, which may arise (or which may be alleged to have arisen) out of or in connection with the work covered by the Agreement. The foregoing indemnity (together with Contractor's obligation to defend) shall apply unless it shall be found by a court of competent jurisdiction that such injury, death, or damage shall have been caused solely by the negligence of the City of Wood Dale, its officers and employees, or any of them. The City of Wood Dale shall be entitled to withhold from any payment otherwise due pursuant to the Agreement such amount or amounts as may be reasonably necessary to protect it against liability from any personal injury, death, or property damage resulting from the performance of the work hereunder.

CITY OF WOOD DALE
Fuel Tank Replacement Project

-SPECIAL INSTRUCTIONS-

1. Return With Bid:
 - a) Cover Sheet;
 - b) Signed Proposal;
 - c) Bid guarantee consisting of a bid bond, a cashier's check, or certified check in an amount not less than ten percent (10%) of the amount of the bid;
 - d) Completed Disclosure of Beneficiaries Form;
 - e) Signed Certification Forms;
 - f) Completed References Form listing similar projects; and
 - g) Location and description of Bidder's office or permanent place of business.

RETURN WITH BID

**CITY OF WOOD DALE
Fuel Tank Replacement Project**

-PROPOSAL-

Honorable Mayor and City Council
City of Wood Dale
404 N. Wood Dale Road
Wood Dale, IL 60191

Ladies and Gentlemen:

The undersigned does hereby state he has examined the Notice to Bidders, Instructions to Bidders, Special Instructions, General Requirements, Proposal, Sample Contract, Technical Specifications, Certifications, and all other documents, and all work shall be done in accordance with the documents contained herein.

The undersigned does hereby propose to furnish all labor, services, materials, supplies, equipment, apparatus, appliances and to do all work and pay all costs and expenses connected therein required to complete this order in accordance with the documents named in the foregoing paragraph, on the basis of the quantities of work and services actually performed and for the unit prices stated herein below.

Name of Company: Crowne Industries, Ltd.

Address: 651 S Sutton Road, #214

City, State, Zip: Streamwood, IL 60107

Signed:  Robert Sumoski Date: September 14, 2022

Title: President

****Continued on next page****

RETURN WITH BID

BID SHEET

The undersigned, having become familiar with the specifications and with local conditions affecting the cost of the work, hereby proposes and agrees, if this bid is accepted, to enter into an agreement with the City in the form included in the contract documents for the contract sum and within the contract time indicated in this bid and in accordance with other terms and conditions of the contract documents, and in so doing, to provide and furnish all the labor, equipment, materials, supplies, hardware, necessary tools, expendable equipment and supplies, and all utility and transportation services necessary to perform and complete, in a first-class manner, the entire work in conjunction with the Fuel Tank Replacement Project.

In accordance with the complete specifications, the following amount constitutes as a total sum of the bid:

Fuel Tank Replacement Program

| ITEM | DESCRIPTION | ESTIMATED QUANTITY | UNIT | UNIT PRICE | AMOUNT |
|---------------|---------------------------------|--------------------|------|-------------|--|
| 1. | ABOVE GROUND FUEL STORAGE TANKS | 1 | Each | \$27,969.00 | \$ 27,969.00 |
| TOTAL: | | | | | \$ 27,969.00 (Twenty Seven Thousand, Nine Hundred Sixty Nine Dollars and 00/100) |

RETURN WITH BID

Accompanying this Proposal is a proposal guarantee in the amount of \$ BID BOND (10%) which is hereby tendered in accordance with the requirement of the Instructions to Bidders and the Specifications and/or Special Provisions. If this proposal is accepted and the undersigned fails to execute a contract as required herein, it is hereby agreed that the proposal guarantee shall become the property of the City of Wood Dale, and shall be considered as payment of damages due to delay and other consequences suffered by the City of Wood Dale due to the failure to execute said contract.

The undersigned acknowledges receipt of addenda as follows:

Addendum, No. 1, dated 9/14/2022

No. _____, dated _____

No. _____, dated _____

This bid is an offer which shall be considered accepted only after the Corporate Authorities authorize the execution of the contract. In the event that this proposal is accepted and an award of contract is made to the undersigned bidder, the undersigned does hereby covenant and agree to deliver to the Owner the signed and executed Contract as specified in the Instructions to Bidders and Specifications within ten (10) days after the date of such acceptance and notification thereof.

The proposal shall be binding for sixty (60) days following the bid opening date unless the bidder, upon request of the City of Wood Dale, agrees to an extension.

THIS BID, WHEN ACCEPTED AND SIGNED BY AN AUTHORIZED SIGNATORY OF THE CITY, SHALL BECOME A CONTRACT BINDING UPON BOTH THE PERSON, PARTNERSHIP, OR CORPORATION TO SUPPLY OR PERFORM AS SPECIFIED AND UPON THE CITY TO ACCEPT THE PRODUCT OR SERVICE.

RETURN WITH BID

The undersigned further agrees to begin work within ten (10) working days after the executions and acceptance of the Contract, and thereafter to carry on the work diligently and continuously in such manner as to insure final completion and delivery to the Owner of the entire work under contract in accordance with the provisions of the Contract and Detailed Specifications.

Witness my Hand(s) and Seal this 14 day of September, 2022.
my/our

If an individual, sign _____
and give address. Address _____

If partnership, sign all individual names and give address of each partner. _____
Partnership Name

Name and address of individual partners. _____

If corporation, officers duly authorized should sign, attach corporate seal. _____
Crowne Industries, Ltd.
Corporate Name

ATTEST: _____ Robert Sumoski

Address: 651 S Sutton Rd., #214, Streamwood, IL 60107

By: Nancy McCreary Nancy McCreary
Secretary

-CORPORATE SEAL-

CITY OF WOOD DALE
Fuel Tank Replacement Project
CONTRACT

This CONTRACT, made and entered into this _____ day of _____, 2022, by and between the CITY OF WOOD DALE, an Illinois municipal corporation (hereinafter “City”), and _____, an Illinois corporation (hereinafter “Contractor”);

RECITALS

WHEREAS, the City desires to engage the Contractor to provide (hereinafter “Work”), located within the corporate limits of the City of Wood Dale; and

WHEREAS, the Contractor represents itself to be in compliance with Illinois Statutes relating to all matters affecting its status as a corporation operating as a general contractor within the State of Illinois and to have the necessary expertise and experience to furnish such services for the Work upon the terms and conditions set forth herein below:

NOW, THEREFORE, in consideration of the mutual promises herein contained, it is hereby agreed by and between the City and the Contractor that:

I. SCOPE OF SERVICES

The Scope of Services shall be as set forth in the “Notice to Bidders”, “Instructions to Bidders”, “Special Instructions”, “Technical Specifications”, “General Requirements”, “Specifications”, and “Special Provisions” prepared by the City. Should there be a conflict in terms between this Contract and the other documents, which are a component part hereof, this Document shall control.

II. PERFORMANCE OF WORK

The Contractor shall perform all work, furnishing all materials and labor, and shall abide by the terms of this Contract and the requirements of the City. Contractor must complete, in its entirety, the project within one (1) calendar month, weather permitting, from the date the City provides Contractor with notice to proceed.

III. PAYMENT TO THE CONTRACTOR

For the Work, the Contractor shall be paid in accordance with the Proposal. The City shall make payments to the Contractor within 30 days after completion of the Work and upon receipt of an invoice in a format approved by the City.

This contract calls for the construction of a “public work,” within the meaning of the Illinois Prevailing Wage Act, 820 ILCS 130/.01 et seq. (“the Act”). The Act requires contractors and subcontractors to pay laborers, workers and mechanics performing services on public works projects no less than the current “prevailing rate of wages” (hourly cash wages plus amount for fringe benefits) in the county where the work is performed. The Department publishes the prevailing wage rates on its website at <http://labor.illinois.gov/>. The Department revises the prevailing wage rates and the contractor/subcontractor has an obligation to check the

Department's web site for revisions to prevailing wage rates. For information regarding current prevailing wage rates, please refer to the Illinois Department of Labor's website. All contractors and subcontractors rendering services under this contract must comply with all requirements of the Act, including but not limited to, all wage requirements and notice and record keeping duties.

IV. NO CO-PARTNERSHIP OR AGENCY

It is understood that nothing herein contained is intended or shall be construed to, in any respect, create or establish the relationship of co-partners between the City and the Contractor, or as constituting the Contractor as the general representative or general agent for the City for any purpose whatsoever.

V. CONTRACT DOCUMENTS

It is further understood that this Contract consists of the following documents which are hereby made a part hereof: the Notice to Bidders, Instructions to Bidders, Specifications, Special Instructions, Special Provisions, Proposal, Performance Bond, Anti-Collusion Affidavit of Compliance, Americans with Disabilities Act of 1990 Certificate, Policy Against Sexual Harassment Certificate, Hold Harmless Agreement, Anti-bid Rigging Certificate, and Drug-free Workplace Certificate.

VI. MATERIALS AND LABOR/WORKMANSHIP WARRANTY

Upon completion of the Work, and satisfactory acceptance by the City, the Contractor will provide a written one (1) year warranty covering both parts and labor/workmanship. Warranty shall include, but is not limited by this provision, that any defective material(s) and/or defective installation or workmanship will be repaired and/or replaced by Contractor at no cost to the City.

VII. SEVERABILITY

The parties intend and agree that, if any paragraph, subparagraph, phrase, clause, or other provision of this Contract, or any portion thereof, shall be held to be void or otherwise unenforceable, all other portions of this Contract shall remain in full force and effect.

VIII. HEADINGS

The headings of the several paragraphs of this Contract are inserted only as a matter of convenience and for reference and in no way are they intended to define, limit, or describe the scope or intent of any provision of this Contract, nor shall they be construed to affect in any manner the terms and provisions hereof or the interpretation or construction thereof.

IX. MODIFICATION OR AMENDMENT

This Contract constitutes the entire contract of the parties on the subject matter hereof and may not be changed, modified, discharged, or extended except by written amendment duly executed by the parties. Each party agrees that no representations or warranties shall be binding upon the other party unless expressed in writing herein or in a duly executed amendment hereof, or Change Order as herein provided.

XX. APPLICABLE LAW

This Contract shall be deemed to have been made in, and shall be construed in accordance with the laws of the 18th Judicial Circuit Court of DuPage County, State of Illinois.

XXI. NEWS RELEASES

The Contractor may not issue any news releases without prior approval from the City Manager nor will the Contractor make public proposals developed under this Contract without prior written approval from the City Manager prior to said documentation becoming a matter of public record.

XXII. COOPERATION WITH OTHER CONTRACTORS

The Contractor shall cooperate with any other Contractors in the City's employ or any matter associated with the Work.

XXIII. NOTICES

All notices, reports and documents required under this Contract shall be in writing and shall be mailed by first class mail, postage prepaid, addressed as follows:

If to City:

Jeffrey Mermuys
City Manager
404 N. Wood Dale Road
Wood Dale, Illinois 60191

With a copy to:

Lynn Curiale
City Clerk
404 N. Wood Dale Road
Wood Dale, Illinois 60191

If to Contractor:

IN WITNESS WHEREOF, the undersigned have placed their hands and seals hereto on the date first above written.

CITY OF WOOD DALE:

ATTEST:

Annunziato Pulice, Mayor

City Clerk

CONTRACTOR:

ATTEST:

By _____

By _____

Its _____

RETURN WITH BID

**CITY OF WOOD DALE
Fuel Tank Replacement Project
-DISCLOSURE OF BENEFICIARIES-**

In compliance with City of Wood Dale Purchasing Procedures requiring the disclosure of certain interests by persons applying for permits, licenses, approval, or benefits from the City of Wood Dale:

1. Applicant: Crowne Industries, Ltd., Robert Sumoski
Name
651 S Sutton Rd., #214, Streamwood, IL 60107
Address

2. Nature of Transaction Sought; for example, license permit approval or sale of products, services, or miscellaneous (explain miscellaneous):

Sale of products/service for tank replacement project

3. Nature of Applicant: (Please check one)

- a. Natural Person: _____
- b. Corporation: _____
- c. Land Trust/Trustee: _____
- d. Trust/Trustee: _____
- e. Partnership: _____
- f. Joint Venture: _____

4. If applicant is an entity other than described in Section 3, briefly state the nature and characteristics of the applicant:

5. If in your answer to Section 3 you have checked Box b, c, d, or e, identify by name and address each person or entity who is a 7.5 percent shareholder in the case of a corporation, a beneficiary in the case of a trust or land trust, a joint venturer in the case of a joint venture, or who otherwise has a proprietary interest, interest-in profits and losses, or right to control such entity.

Name Address Interest

- a. Robert Sumoski 651 S Sutton Rd., #214 Streamwood, IL 60107 - Owner
- b. _____
- c. _____

6. Name, address, and capacity of person making this disclosure on behalf of the applicant:

IMPORTANT NOTE: In the event your answer to Section 5 identifies entities other than a natural person, additional disclosures are required for each such entity.

VERIFICATION

I, Robert Sumoski, being first duly sworn under oath, depose and state that I am the person making this disclosure on behalf of the applicant, that I am duly authorized to make this disclosure, that I have read the above and foregoing Disclosure of Beneficiaries, and that the statements contained therein are true in both substance and fact.

By:  /Owner
(Authorized Signature and Title)

Subscribed and sworn to before me this 14th day

of September, 2022.

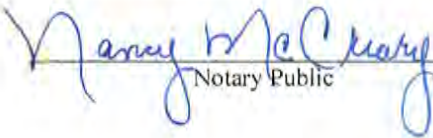
Notary Public



CITY OF WOOD DALE
Fuel Tank Replacement Project
BID CERTIFICATION FORM

RE: CERTIFICATION OF BIDDER, COMPLIANCE WITH SECTION 33E-11
OF ILLINOIS CRIMINAL CODE OF 1961

I/we hereby certify that Crowne Industries, Ltd. is not barred from bidding on this contract as the result of a violation of either Section 33E-3 or 33E-4 of this Article of the Illinois Criminal Code of 1961.

Signed:  Robert Sumoski

Date: 9/14/2022

Title: President

**INTERFERENCE WITH PUBLIC CONTRACTING - - BID RIGGING AND
ROTATING - - KICKBACKS - - BRIBERY**

PUBLIC ACT 85-1295
S.B. 2002

AN ACT to add Article 33E to the "Criminal Code of 1961", approved July 28, 1961, as amended. Be it enacted by the People of the State of Illinois, represented in the General Assembly: Section 1: Article 33E is added to the "Criminal Code of 1961", approved July 28, 1961, as amended, the added Article to read as follows:

ARTICLE 33E. PUBLIC CONTRACTS

Sec. 33E-3 Bid-rigging. A person commits the offense of bid-rigging when he knowingly agrees with any person who is, or but for such agreement would be, a competitor of such person concerning any bid submitted or not submitted by such person or another to a unit of State or local government when with the intent that the bid submitted or not submitted will result in the award of a contract to such person or another and he either (1) Provides such person or receives, from another, information be disclosed to a competitor in an independent, noncollusive submission of bids or (2) Submits a bid that is off such a price, or other material terms, that he does not intend the bid to be accepted.

Bid-rigging is a Class 3 felony. Any person convicted of this offense shall be barred for 5 years from the date of conviction from bidding on any contract offered for bid by any unit of State or local government.

Sec 33E-4. Bid rotating. A person commits the offense of bid rotating when pursuant to any collusive scheme or agreement with another. He engages in a patter over time (which, for the purposes of this Section, shall include at least 3 contract bids within a period of 10 years, the most recent of which occurs after the effective date of this amendatory Act of 1988) of submitting sealed bids to units of State or local government with the intent that the award of such bids rotates, or is

distributed among persons or business entities which submit bids on a substantial number of the same contracts. Bid rotating is a Class 2 felony. Any person convicted of this offense shall be permanently barred from bidding on public contracts in the State of Illinois.

Bidder hereby certifies:

- A. That this bid is genuine and it not made in the interest of or on behalf of any undisclosed person, firm or corporation and is not submitted in conformity with any agreement or rules of any group, association, organization or corporation.
- B. That he has not directly or indirectly induced or solicited any other bidder to put in a false or sham bid.
- C. That he has not solicited or induced any person, firm, or corporation to refrain from bidding.
- D. That he has not sought by collusion or otherwise to obtain for himself any advantage over any other bidder or over the Owner.
- E. That he is not barred from bidding for this Contract as a result of a violation of Section 33E-3 or Section 33E-4 of the Illinois Criminal Code of 1961 (Ill. Rev Stat. ch. 38, Paragraph 33E-1 et seq.).

SUBMITTED: Robert Sumoski

DATE: 9/14/2022

FIRM NAME: Crowne Industries, Ltd. (SEAL)

ADDRESS: 651 S Sutton Rd., #214, Streamwood, IL 60107

SIGNED BY:  9-14-22

(Signature and Date)

President

(Title)

ATTEST:  /Nancy McCreary

(Secretary)

Subscribed and sworn to before me this 14th day of September 2022.

(Notary Public)

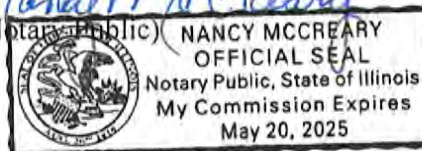

**CITY OF WOOD DALE
Fuel Tank Replacement Project
CERTIFICATION**

Robert Sumoski (hereinafter referred to as "Contractor")
having submitted a bid/proposal for Crowne Industries, Ltd. to the City of Wood Dale,
DuPage County, Illinois, for Fuel Tank Replacment Project, hereby certifies
that:

5/2-105(A) (4) including the following information:

1. An acknowledgement of the illegality of sexual harassment.
2. The definition of sexual harassment under State law.
3. A description of sexual harassment, utilizing examples.
4. The contractor's internal complaint process, including penalties.
5. The legal recourse, investigative and complaint process available through the Illinois Department of Human Rights and the Human Rights Commission.
6. Directions on how to contact the Department of the Commission.
7. An acknowledgement of protection of a complainant against retaliation as provided in Section 6-101 of the Human Rights Act.

Each contractor must provide a copy of such written policy to the Illinois Department of Human Rights upon request.

By:  /Robert Sumoski
Authorized Agent of Contractor

Subscribed and sworn to before me on this 14th day of September 2022.

Notary Public

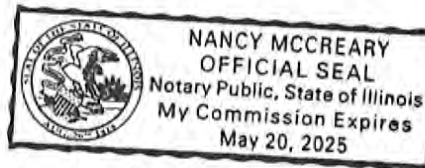

CITY OF WOOD DALE
Fuel Tank Replacement Project
CONTRACTOR'S DRUG-FREE WORKPLACE CERTIFICATION

Pursuant to Ill. Rev. Stat. ch. 127 paragraph 132.311 et. seq. ("Drug Free Workplace Act), the undersigned contractor hereby certifies to the contracting agency that it will provide a drug-free workplace by:

- (a) Publishing a statement:
 - (1) Notifying employees that the unlawful manufacture, distribution, dispensation, possession, or use of a controlled substance, including cannabis, is prohibited in the grantee's of contractor's workplace.
 - (2) Specifying the actions that will be taken against employees for violations of such prohibition.
 - (3) Notifying the employee that, as a condition of employment on such contract or grant, the employee will:
 - (A) Abide by the terms of the statement; and
 - (B) Notify the employer of any criminal drug statute conviction for a violation occurring in the workplace no later than five (5) days after such conviction.
- (b) Establishing a drug free awareness program to inform employees about:
 - (1) The dangers of drug abuse in the workplace;
 - (2) The grantee's or contractor's policy of maintaining drug-free workplace;
 - (3) Any available drug counseling, rehabilitation, and employee assistance program; and
 - (4) The penalties that may be imposed upon employees for drug violation.
- (c) Making it a requirement to give a copy of the statement required by subsection (a) to each employee engaged in the performance of the contract or grant and to post the statement in a prominent place in the workplace.
- (d) Notifying the contracting agency within ten (10) days after receiving notice under par (B) of paragraph (3) of subsection (a) from an employee or otherwise receiving actual notice of such conviction.

Dated: September 14, 2022

By:  /Robert Sumoski
Authorized Agent of Contractor

RETURN WITH BID

CITY OF WOOD DALE Fuel Tank Replacement Project

CERTIFICATIONS

Robert Sumoski, being first duly sworn, deposes and states that he is President of Crowne Industries, Ltd. (Partner, Officer, Owner, etc.) (Corporation / Company)

and that he is cognizant of the following statutory requirements and under penalty of perjury and certifies the following:

Anti-Collusion Affidavit of Compliance: That bid is genuine and not collusive or sham; that said bidder has not colluded, conspired, connived or agreed directly or indirectly with any bidder or person to put in a sham bid or to refrain from bidding; and has not in any manner directly or indirectly sought by agreement or collusion or communication or conference with any person to fix the bid price element of said bid or that of any other bidder; or to secure any advantage against any other bidder or any person interested in the proposed contract.

Public Act 85-1295: That bidder is not barred from bidding on this contract as a result of a violation of either Section 33E-3 or 33E-4 of P.A. 85-1295 (720ILCS 5).

Public Act 86-1039: That bidder is not barred from contracting with the City of Wood Dale because of any delinquency in the payment of any tax administered by the Department of Revenue unless the individual or entity is contesting, in accordance with the procedures established by the appropriate revenue act, liability for the tax, or the amount of the tax (65ILCS 5/11-42.1-1).

Public Act 86-1459: That bidder will provide a drug free workplace in accordance with the Illinois Drug Free Workplace Act (30ILCS 580/2).

Illinois Human Rights Act: That bidder is presently in compliance and agrees to comply with all applicable provisions of the Illinois Human Rights Act, together with all rules and regulations promulgated and adopted pursuant thereto (775ILCS 5/1 -101 et seq.).

Equal Employment Opportunities-Affirmative Action: That bidder is presently in compliance and agrees to comply with all applicable provisions of Equal Employment Opportunities--Affirmative Action (775ILCS 5/2-105 [A]).

Americans with Disabilities Act of 1990: That bidder is presently in compliance and agrees to comply with all applicable provisions of the Americans with Disabilities Act of 1990 together with all rules and regulations promulgated and adopted pursuant thereto.

INDIVIDUAL:

Signature of Bidder: _____

Business Address: _____

Business Phone Number: _____

PARTNERSHIP:

Partnership Name: _____

Signed By: _____

Business Address: _____

Business Phone Number: _____

Insert Names and Addresses of All Partners: _____

CORPORATION:

Corporate Name: Crowne Industries, Ltd.

Signed By:  Robert Sumoski

Title: President

Business Address: 651 S Sutton Rd, #214, Streamwood, IL 60107

Business Phone Number: 630-497-9009

Insert Names of Corporate Officers

President: Robert Sumoski

Secretary: _____

Treasurer: _____

Attest: Nancy McCreary

RETURN WITH BID

**CITY OF WOOD DALE
Fuel Tank Replacement Project**

-REFERENCES-

Name of Bidding Firm: Crowne Industries, Ltd.
(Please print)

The Contractor must list three (3) references with needs similar to the City of Wood Dale for whom Contractor has supplied the materials and services for which he is bidding on this contract within the last three years. Please include name, address, telephone number, contact person, and type of work you performed for that entity.

1. Company Name/Municipality: Village of Westmont
Address: 6015 S Avenue, Westmont, IL 60559
Phone: 630.981.6289
Contact Person: Mike Ramsey
Type of Work: UST Fuel System Installation

2. Company Name/Municipality: City of Wilmette
Address: 711 Laramie, Wilmette, IL 60091
Phone: 847.853.7583
Contact Person: Kurt Smith
Type of Work: Fuel System Installation

3. Company Name/Municipality: City of Park Ridge
Address: 400 Busse Highway, Park Ridge, IL
Phone: 847.318.5242
Contact Person: Bob Melerski
Type of Work: Fuel Monitoring Replacement

CITY OF WOOD DALE
Fuel Tank Replacement Project
Scope of Work/Specifications

Scope of Work

The City of Wood Dale desires to remove one 2500 gallon split fuel tank and purchase and have installed a new 2500 gallon gasoline above ground fuel tank, pump and dispenser mechanism. The location of the tank is 720 N Central Ave. Wood Dale, IL 60191.

The City of Wood Dale shall provide the following:

- Concrete Pad with Protective Bollards
- Electrical Service to the Pad
- Heavy duty high hose retractors
- ¾ breakaways with six inch whip hoses
- One (1) Phoenix AFC Fuel Control System
- Pulsars.

The Contractor shall furnish and install the following fuel system equipment:

- One (1) 2,500 gallon Flameshield double wall above ground steel storage tank or approved equal for gasoline. The tank shall meet NFPA standard 30/30a for fire resistant AST. The tank shall be rated for 2 hours at 2000°F. The tank shall have emergency vents.
- Fill caps with adaptors.
- Sight gauges.
- Regular vents with 4' pipe.
- Leak gauges
- One (1) Fill-Rite model #313 ¾ HP utility pump, or approved equal, for AST with Anti-siphon device for gasoline.
- Fill-Rite model #FR305R, or approved equal, AST remote dispensers with 900 series, or approved equal, meters.
- Two ¾ inch curb hoses with couplers of sufficient length to work with the existing high hose retractors.
- One automatic nozzle
- One ¾ filter setups
- Miscellaneous piping, couplers, fittings as necessary to complete the installation
- All electrical work necessary to connect the fuel dispensing system and fuel control system.
- Installation shall be performed following all applicable manufacture instructions

Flameshield® Guideline Specification

A) General

1. Provide Flameshield® 2-hour 2000° fire-tested double-wall aboveground storage tanks.

B) Labeling

1. Tanks shall bear the Steel Tank Institute Flameshield® identification label.
2. Aboveground tanks shall bear Southwest Research Institute 97-04 label.

C) Product Description

1. Tanks shall be manufactured in accordance with Steel Tank Institute Flameshield® Standard for Aboveground Tanks.
2. Aboveground tank primary and secondary containment (inner and outer walls) shall be manufactured in accordance and listed with Underwriters Laboratories UL 142, Standard for Steel Aboveground Tanks for Flammable and Combustible Liquids.
3. Integral secondary containment shall be testable and provide access for interstitial leak detection monitoring.
4. Listed supports shall be used for all horizontal, rectangular and vertical tanks. Supports are designed for seismic loading, if necessary.

D) Manufacturer

1. Manufacturer shall be a licensed member company of the Steel Tank Institute and subject to Steel Tank Institute's Quality Assurance program.

Flameshield® is available from an extensive group of Steel Tank Institute fabricators who participate in the STI Quality Assurance Program. Under the program, independent quality control inspectors make unannounced visits to STI members, ensuring fabrication to the highest possible standards.



A division of STI/SPFA 944 Donata Court Lake Zurich, IL 60047 Ph: (847)438-8265 Fx: (847)438-8766 Web: www.steeltank.com

This work shall be performed on a **Lump Sum** basis for **ABOVE GROUND FUEL STORAGE TANKS** and shall include all labor, materials and equipment necessary to provide and install the new fuel storage tanks and appurtenances and integrate them with the City supplied equipment.

FUEL SUPPLY CONTRACT

Purchase of the above ground storage tanks and associated equipment shall in no way obligate the City to purchase fuel from a particular supplier.

The City reserves the right to negotiate a fuel supply contract with any supplier of its choosing.

Drawings

| BILL OF MATERIALS | | BILL OF MATERIALS | |
|-------------------|------|---|--|
| ITEM | QTY. | DESCRIPTION | DESCRIPTION |
| A1 | 2 | REG. 1 1/4" x 5/8" x 24" FLANGE INNER | THREADED WELD FLANGE 48" O.D. EXTERIOR |
| A2 | 2 | REG. 1 1/4" x 5/8" x 24" FLANGE OUTER | THREADED WELD FLANGE 48" O.D. EXTERIOR |
| A3 | 1 | COL. 7 1/2" x 12" x 12" x 12" LONG (RND) HELL | INSULATION, WOODPINE, THERMAL 2500 (LAL 79 100 RL) |
| A4 | 2 | COL. 7 1/2" x 12" x 12" x 12" LONG (RND) HELL | THREADED WELD FLANGE 48" O.D. EXTERIOR W/O |
| A5 | 2 | SPR. 7 1/2" x 12" x 12" x 12" LONG | PIPE 48" O.D. x 12" LONG (TIE) EXTERIOR W/O |
| A6 | 2 | HT. LUG. 1 1/2" x 1 1/2" x 1 1/2" x 1 1/2" | PIPE 48" O.D. x 12" LONG (TIE) |
| A7 | 1 | HT. LUG. 1 1/2" x 1 1/2" x 1 1/2" x 1 1/2" | PIPE 48" O.D. x 12" LONG (TIE) |
| A8 | 1 | THREADED WELD FLANGE 48" O.D. | PUMP MANWAY 12" x 12" x 48" O.D. FULL CO-PLANAR |
| A9 | 1 | UNCL. 1 1/2" x 1 1/2" x 1 1/2" x 1 1/2" | |
| A10 | 1 | UNCL. 1 1/2" x 1 1/2" x 1 1/2" x 1 1/2" | |

VENTING CAPACITY PRIMARY TANK: 225,370 CU. FT./HR.
 VENTING CAPACITY SECONDARY TANK: 240,000 CU. FT./HR.

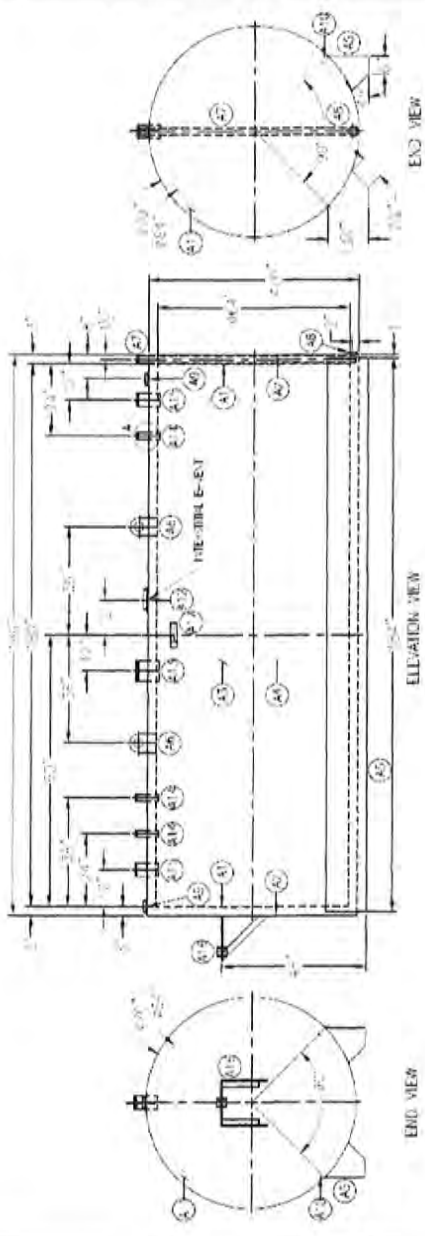
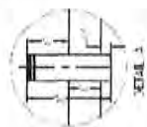



Bid Bond

CONTRACTOR:

(Name, legal status and address)

**Crowne Industries, Ltd.
651 South Sutton Road #214
Streamwood, IL 60107**

SURETY:

(Name, legal status and principal place of business)

**Merchants National Bonding, Inc.
PO Box 14498
Des Moines, IA 50306-3498**

OWNER:

(Name, legal status and address)

**City of Wood Dale
404 N. Wood Dale Road
Wood Dale, IL 60191**

This document has important legal consequences. Consultation with an attorney is encouraged with respect to its completion or modification.

Any singular reference to Contractor, Surety, Owner or other party shall be considered plural where applicable.

BOND AMOUNT: Ten Percent (10%) of Amount Bid

PROJECT:

(Name, location or address, and Project number, if any)

**Fuel Tank Replacement Project
Wood Dale, IL**

The Contractor and Surety are bound to the Owner in the amount set forth above, for the payment of which the Contractor and Surety bind themselves, their heirs, executors, administrators, successors and assigns, jointly and severally, as provided herein. The conditions of this Bond are such that if the Owner accepts the bid of the Contractor within the time specified in the bid documents, or within such time period as may be agreed to by the Owner and Contractor, and the Contractor either (1) enters into a contract with the Owner in accordance with the terms of such bid, and gives such bond or bonds as may be specified in the bidding or Contract Documents, with a surety admitted in the jurisdiction of the Project and otherwise acceptable to the Owner, for the faithful performance of such Contract and for the prompt payment of labor and material furnished in the prosecution thereof; or (2) pays to the Owner the difference, not to exceed the amount of this Bond, between the amount specified in said bid and such larger amount for which the Owner may in good faith contract with another party to perform the work covered by said bid, then this obligation shall be null and void, otherwise to remain in full force and effect. The Surety hereby waives any notice of an agreement between the Owner and Contractor to extend the time in which the Owner may accept the bid. Waiver of notice by the Surety shall not apply to any extension exceeding sixty (60) days in the aggregate beyond the time for acceptance of bids specified in the bid documents, and the Owner and Contractor shall obtain the Surety's consent for an extension beyond sixty (60) days.

If this Bond is issued in connection with a subcontractor's bid to a Contractor, the term Contractor in this Bond shall be deemed to be Subcontractor and the term Owner shall be deemed to be Contractor.



By arrangement with the American Institute of Architects, the National Association of Surety Bond Producers (NASBP) (www.nasbp.org) makes this form document available to its members, affiliates, and associates in Microsoft Word format for use in the regular course of surety business. NASBP vouches that the original text of this document conforms exactly to the text in AIA Document A310-2010, Bid Bond. Subsequent modifications may be made to the original text of this document by users, so careful review of its wording and consultation with an attorney are encouraged before its completion, execution or acceptance.

When this Bond has been furnished to comply with a statutory or other legal requirement in the location of the Project, any provision in this Bond conflicting with said statutory or legal requirement shall be deemed deleted herefrom and provisions conforming to such statutory or other legal requirement shall be deemed incorporated herein. When so furnished, the intent is that this Bond shall be construed as a statutory bond and not as a common law bond.

Signed and sealed this 13th day of September, 2022.

Crowne Industries, Ltd.

(Principal)

(Seal)

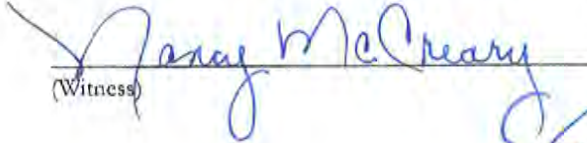

(Witness)



(Title) /President

Merchants National Bonding, Inc.

(Surety)

(Seal)

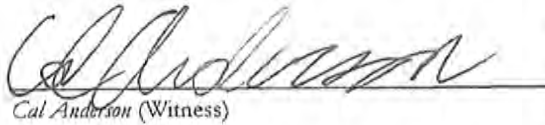

Cal Anderson (Witness)



Jack Anderson, Attorney-in-Fact



By arrangement with the American Institute of Architects, the National Association of Surety Bond Producers (NASBP) (www.nasbp.org) makes this form document available to its members, affiliates, and associates in Microsoft Word format for use in the regular course of surety business. NASBP vouches that the original text of this document conforms exactly to the text in AIA Document A310-2010, Bid Bond. Subsequent modifications may be made to the original text of this document by users, so careful review of its wording and consultation with an attorney are encouraged before its completion, execution or acceptance.

ACKNOWLEDGMENT OF PRINCIPAL (Individual)

State of _____ }
County of _____ }

On this _____ day of _____, in the year _____, before me personally comes _____, to me known and known to me to be the person who is described in and executed the foregoing instrument, and acknowledges to me that he/she executed the same.

Notary Public

ACKNOWLEDGMENT OF PRINCIPAL (Partnership)

State of _____ }
County of _____ }

On this _____ day of _____, in the year _____, before me personally come(s) _____, a member of the co-partnership of _____, to me known and known to me to be the person who is described in and executed the foregoing instrument, and acknowledges to me that he/she executed the same as the act and deed of the said co-partnership.

Notary Public

ACKNOWLEDGMENT OF PRINCIPAL (Corporation/LLC)

State of Illinois }
County of Cook }

On this 13th day of September, in the year 2022, before me personally come(s) Robert Sumoski, to me known, who being duly sworn, deposes and says that he/she resides in the City of Streamwood that he/she is the President of the Crowne Industries, Ltd., the corporation described in and which executed the foregoing instrument, and that he/she signed his/her name thereto by like order.

Nancy McCreary
Notary Public

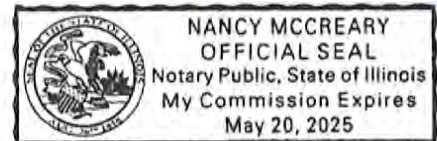

MERCHANTS
BONDING COMPANY
POWER OF ATTORNEY

Know All Persons By These Presents, that MERCHANTS BONDING COMPANY (MUTUAL) and MERCHANTS NATIONAL BONDING, INC., both being corporations of the State of Iowa (herein collectively called the "Companies") do hereby make, constitute and appoint, individually, Jack Anderson; Rita Jorgenson

their true and lawful Attorney(s)-in-Fact, to sign its name as surety(ies) and to execute, seal and acknowledge any and all bonds, undertakings, contracts and other written instruments in the nature thereof, on behalf of the Companies in their business of guaranteeing the fidelity of persons, guaranteeing the performance of contracts and executing or guaranteeing bonds and undertakings required or permitted in any actions or proceedings allowed by law.

This Power-of-Attorney is granted and is signed and sealed by facsimile under and by authority of the following By-Laws adopted by the Board of Directors of Merchants Bonding Company (Mutual) on April 23, 2011 and amended August 14, 2015 and adopted by the Board of Directors of Merchants National Bonding, Inc., on October 16, 2015.

"The President, Secretary, Treasurer, or any Assistant Treasurer or any Assistant Secretary or any Vice President shall have power and authority to appoint Attorneys-in-Fact, and to authorize them to execute on behalf of the Company, and attach the seal of the Company thereto, bonds and undertakings, recognizances, contracts of indemnity and other writings obligatory in the nature thereof."

"The signature of any authorized officer and the seal of the Company may be affixed by facsimile or electronic transmission to any Power of Attorney or Certification thereof authorizing the execution and delivery of any bond, undertaking, recognizance, or other suretyship obligations of the Company, and such signature and seal when so used shall have the same force and effect as though manually fixed."

In connection with obligations in favor of the Florida Department of Transportation only, it is agreed that the power and authority hereby given to the Attorney-in-Fact includes any and all consents for the release of retained percentages and/or final estimates on engineering and construction contracts required by the State of Florida Department of Transportation. It is fully understood that consenting to the State of Florida Department of Transportation making payment of the final estimate to the Contractor and/or its assignee, shall not relieve this surety company of any of its obligations under its bond.

In connection with obligations in favor of the Kentucky Department of Highways only, it is agreed that the power and authority hereby given to the Attorney-in-Fact cannot be modified or revoked unless prior written personal notice of such intent has been given to the Commissioner-Department of Highways of the Commonwealth of Kentucky at least thirty (30) days prior to the modification or revocation.

In Witness Whereof, the Companies have caused this instrument to be signed and sealed this 11th day of February, 2020.



MERCHANTS BONDING COMPANY (MUTUAL)
MERCHANTS NATIONAL BONDING, INC.

By *Larry Taylor*
President

STATE OF IOWA
COUNTY OF DALLAS ss.

On this 11th day of February, 2020, before me appeared Larry Taylor, to me personally known, who being by me duly sworn did say that he is President of MERCHANTS BONDING COMPANY (MUTUAL) and MERCHANTS NATIONAL BONDING, INC.; and that the seals affixed to the foregoing instrument are the Corporate Seals of the Companies; and that the said instrument was signed and sealed in behalf of the Companies by authority of their respective Boards of Directors.

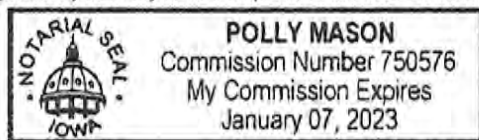

Polly Mason
Notary Public

(Expiration of notary's commission does not invalidate this instrument)

I, William Warner, Jr., Secretary of MERCHANTS BONDING COMPANY (MUTUAL) and MERCHANTS NATIONAL BONDING, INC., do hereby certify that the above and foregoing is a true and correct copy of the POWER-OF-ATTORNEY executed by said Companies, which is still in full force and effect and has not been amended or revoked.

In Witness Whereof, I have hereunto set my hand and affixed the seal of the Companies on this 13th day of September, 2022.



William Warner Jr.
Secretary

ACKNOWLEDGEMENT OF SURETY

STATE OF MINNESOTA

COUNTY OF CHIPPEWA

}

On this 13th day of September, 2022, before me, a Notary Public within and for said County, personally appeared **Jack Anderson** to me personally known, who being by me duly sworn he/she did say that he/she is the attorney-in-fact of **Merchants National Bonding, Inc.**, the corporation named in the foregoing instrument, and the seal affixed to said instrument is the corporation seal of said corporation, and sealed on behalf of said corporation by authority of its Board of Directors and said **Jack Anderson** acknowledged said instrument to be the free act and deed of said corporation.

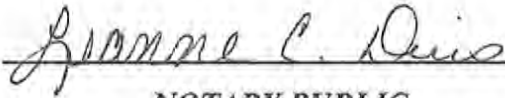

NOTARY PUBLIC
My Commission Expires
1/31/2023





REQUEST FOR COMMITTEE ACTION

Referred to Committee: September 22, 2022
Subject: Mondo Board Purchase
Staff Contact: Michael Stenson, IT Director;
Alan Lange, Public Works Director
Department: Information Technology and Public Works

TITLE: Approval of a Purchase Agreement Between the City of Wood Dale and IT Savvy for the Mondo Board Project at City Hall and Public Works in an Amount Not to Exceed \$23,200.

RECOMMENDATION:

Staff Recommends the approval of a purchase agreement between the City of Wood Dale and IT Savvy for the Mondo Board Project at City Hall and Public Works in an amount not to exceed \$23,200. The Mondo Boards will replace existing end of life equipment in the City Council Chambers and the Executive Session meeting room. This equipment will allow for Zoom meetings, Council presentations including the potential for interactive presentations at future meetings. The Mondo Boards purchased for the new Public Works Facility will also offer interactive training and conference meeting capability.

BACKGROUND:

The City has budgeted to install teleconference technology for the new Public Works facility and also upgrade the Council Chambers and Executive Session conference room for PEG access, teleconference, and video production technology.

ANALYSIS:

The City budgeted for technology upgrades during FY 2023. The Comcast PEG fee will fund the Mondo Boards for the Council Chambers and the PW Facility Improvement Project will fund the Public Works Mondo Boards. The Mondo Board technology items of this purchase agreement is valued at \$23,200.

Quotes were received by three vendors. Quote results were as follows:

- IT Savvy - \$23,200.00
- PCNation - \$23,682.64.00
- TouchBoards - \$23,781.64

All quotes were reviewed by staff, and IT Savvy was determined to be the lowest responsible bidder. IT Savvy has provided goods and services satisfactorily in the past.

DOCUMENTS ATTACHED

- ✓ IT Savvy quote document
- ✓ PCNation quote document
- ✓ Touchboard quote document



ITsavvy LLC
 313 South Rohlwing Road
 Addison, IL 60101
 www.ITsavvy.com

| Quote Details | |
|-------------------------|-------------|
| Quote #: | 3640943 |
| Date: | 09/15/2022 |
| Payment Method: | Net 30 Days |
| Client PO#: | |
| Cost Center: | |
| Shipping Method: | Ground |

Quote

Bill To:
 ACCT #: 577135
 City of Wood Dale
 404 North Wood Dale Road
 Wood Dale, IL 60191
 United States

Ship To:
 City of Wood Dale
 404 North Wood Dale Road
 Wood Dale, IL 60191
 United States

Client Contact:
 Mike Stenson
 (P) 630-787-3710
 mstenson@wooddale.com

Client Executive:
 Matt Butler
 (P) 630.396.6307
 (F) 630.396.6322
 mbutler@ITsavvy.com

| Item Description | Part # | Qty | Unit Price | Total |
|-------------------------------|----------|-----|------------|-------------|
| 1 98IN I7 MONDOPAD ULTRA BNDL | 22779359 | 2 | \$8,150.00 | \$16,300.00 |
| 2 75IN I7 MONDOPAD ULTRA BNDL | 22779357 | 2 | \$3,450.00 | \$6,900.00 |

| Fair Market Value | | \$1 Buy Out | |
|-------------------|-------------------|-------------------|-------------------|
| 3 Year FMV / Year | 5 Year FMV / Year | 3 Year \$1 / Year | 5 Year \$1 / Year |
| \$7,753.07 | \$5,006.63 | \$8,321.65 | \$5,164.16 |

Lease prices listed above are estimates. They apply for Public School and Municipal Entities only. They are based upon individual credit review and approval. Your final rates will be determined after credit review.

Subtotal: \$23,200.00
 Shipping: \$0.00
TOTAL: \$23,200.00

*Due to an oversized item a freight quote is required.

ITsavvy is always looking to deliver the lowest cost possible to our clients. This results in fluctuating prices that you will find are lower more often than not. However, prices are subject to increases without notice in the event of a manufacturer or distributor price increase. Available inventory is subject to change without notice. This document is a quotation only and is not an order or offer to sell.

We do accept credit cards for payment. However, if the credit card is provided after the order has been invoiced there will be a charge of 3% of the total purchase.

Unless specifically listed above, these prices do NOT include applicable taxes, insurance, shipping, delivery, setup fees, or any cables or cabling services or material.

All non-recurring services are 50% due upon signing of contract, 40% due upon delivery of equipment, balance due upon install.

ITsavvy's General Terms and Conditions of Sale, which can be found at www.ITsavvy.com/termsandconditions, shall apply to and are incorporated into all agreements with Client, including all Orders.

Printed Name: _____ Title: _____

Authorized Signature: _____ Date: _____

Is your organization sales tax exempt? [Click here for information on how to quickly and easily setup your tax-exempt account.](#)

PCNation

Hello. Sign in
Your Account ▾

View
Your Cart (4)

800-235-4050 ▾

Shop All
Categories

Shop All
Brands

Computers & Hardware

Software

Cloud Solutions

Photo & Video

TVs & Electronics

Specials

FREE EXPEDITED 2-DAY DELIVERY ON 100,000+ TECHNOLOGY PRODUCTS. [CLICK FOR DETAILS](#)

Ship to **Wood Dale , 60191** ▾

Your Shopping Cart

Recommendations

| Products | Item(s) | Quantity | Item Price | Item Total |
|----------|--|--------------------------------|------------|------------|
| | Infocus Managed 75IN I7 Mondopad Ultra Bndl | <input type="text" value="2"/> | \$3,551.92 | \$7,103.84 |

PCN# 9JP232 | MFG# INF7500-I7-KIT-5
 Condition : **New and Factory Fresh**
 Availability : **Currently unavailable**
 Expected ship date : **Approximately 2 Weeks**

[Delete](#)



Extended & Accidental Damage Protection Plans Available [Details](#)

2-Year \$265.99

3-Year \$332.99

| | | | | |
|--|--|--------------------------------|------------|-------------|
| | Infocus Managed 98IN I7 Mondopad Ultra Bndl | <input type="text" value="2"/> | \$8,289.40 | \$16,578.80 |
|--|--|--------------------------------|------------|-------------|

PCN# 9JP234 | MFG# INF9800-I7-KIT-5
 Condition : **New and Factory Fresh**
 Availability : **Currently unavailable**
 Expected ship date : **Approximately 2 Weeks**

[Delete](#)



Extended & Accidental Damage Protection Plans Available [Details](#)

2-Year \$462.99

3-Year \$582.99

[Clear Cart](#)

Item Total : **\$23,682.64**

Shipping

Store Pickup
Chicago Superstore

The items in your cart are not available for store pickup.



Acer P414RN-51 TMP414RN-51-54JZ 14 Inch Touchscreen Convertible 2 In 1 Notebook - Full Hd - 1920 X 1080 - Intel

Limited Availability

ACER
\$976.72

[Add to Cart](#)



Acer Travelmate P2 P214-41-G2 TMP214-41-G2-R5EB 14 Inch Notebook - Full Hd - 1920 X 1080 - Amd Ryzen 5 Pro 5650U

Limited Availability

ACER
\$677.82

[Add to Cart](#)



Acer Travelmate P2 P214-41-G2 TMP214-41-G2-R85M 14 Inch Notebook - Full Hd - 1920 X 1080 - Amd Ryzen 7 Pro 5850U

In stock

ACER
\$762.73

[Add to Cart](#)

4.6 ★★★★★
Google
Customer Reviews

Choose a Shipping Method.

- Expedited Ground Delivery FREE
- Fedex 2 Business Day \$1,485.22
- Fedex Next Business Day \$1,887.60
- Fedex Next Business Morning \$2,174.70
- UPS 2 Business Day \$1,883.31
- UPS Next Business Day \$2,179.10

Order Sub-Total : \$23,682.64

Shipping : \$0.00

Order Total : \$23,682.64

PO Number (if any) :

Proceed to Secure Checkout:

[New Customer](#)

[Existing Customer](#)

[Guest Checkout](#)

ABOUT US

- [About PCNation](#)
- [Careers](#)
- [Contact Us](#)
- [News Release](#)

HOW WE CAN HELP

- [Customer Care](#)
- [FAQs](#)
- [Tech Support](#)
- [Showroom](#)

[Our Chicago Area Showroom](#)

MY ACCOUNT

- [Corporate Account](#)
- [Government Account](#)
- [My Account](#)
- [Return Request](#)
- [Wish List](#)

OUR POLICIES

- [Return Policy](#)
- [Terms of Use](#)
- [Terms of Sale](#)
- [Delivery Policy](#)



E-Mail Newsletter Sign up to receive emails on our events & promotions

Enter your E-mail Address



[Privacy Policy](#) | [Terms of Use](#)
Copyright © 1996-2022 PCNation(C). All rights reserved.



BBB Rating: A+
As of 9/15/2022
[Click for Profile](#)





Packet Page #62

Hello Mike,

Thank you for visiting Touchboards, below is the pricing that you have requested.

If there are any questions with your quote, we are here to help and look forward to working with you.

| ITEM | PRICE | QTY | TOTAL |
|--|--------------------------------------|-----|--------------------|
|  <p>InFocus INF7500-i7-KIT 75in - i7 Mondopad Ultra Bundle Weight: 167.40 lbs.</p> | \$5,646.00 \$3,551.92 | 2 | \$7,103.84 |
|  <p>InFocus INF9800-i7-KIT 98in- i7 Mondopad Ultra Bundle Weight: 423.00 lbs.</p> <div style="border: 1px solid #ccc; padding: 5px; margin-top: 10px;"> <p>Special Order Item: No refunds or cancellations</p> </div> | \$13,606.00 \$8,289.40 | 2 | \$16,578.80 |

Terms Credit Card

Total Shipping Weight: ~1,180.80 lbs

Sub Total \$23,682.64

Shipping (Freight Economy with Lift Gate) **\$99.00**

Total (USD) \$23,781.64

Fax / Email Purchase Orders

OR

PLACE ORDER ONLINE

Your Solutions Expert

BILL TO

City of Wood Dale

Mike -

Support@wooddale.co
m

404 North Wood Dale
Road

Wood Dale, IL 60191

United States

6307664900

6307873710

SHIP TO

City of Wood Dale

Mike

404 North Wood Dale
Road

Wood Dale, IL 60191

United States

6307664900

6307873710

Justin

Potignano [1-866-942-6273](tel:1-866-942-6273) Sales@Touchboards.com

Quote Valid for 60 Days Subject to Terms
and Availability

Interworld Highway, LLC - Touchboards.com

Toll-free: 1-866-942-6273 | Local: 732-222-1511

205 Westwood Avenue Long Branch, NJ 07740 · TAX ID: 20-2111443 · Cage Code: 3GLB3 (Small Business) · DUNS: 129870007

These commodities, technology or software cannot be exported from the United States in violation of any U.S. export administration regulations. Diversion from U.S. law is prohibited. [Terms and Conditions](#)