



CITY OF WOOD DALE

STREETSCAPE AND ECONOMIC ENHANCEMENT COMMITTEE **AGENDA**

Date & Time: Monday, April 4, 2022 at 6:30 PM
Location: Wood Dale City Hall
Executive Session (2nd floor)
404 N. Wood Dale Road
Wood Dale, IL 60191
Members: Chairperson Ald. Peter Jakab, Vice-Chair Ald. Michael Curiale, Shashwat Baxi, Mike Melone, Steve Mikos, Linda Lucania
Staff Liaison: Gosia Pociecha, AICP, Senior Planner

I. CALL TO ORDER

II. ROLL CALL

III. BUSINESS ITEM

A. Approval of Meeting Minutes from November 1, 2021

IV. REPORT AND RECOMMENDATION

A. Street Planters - Recommendation

V. OTHER BUSINESS

A. None

VI. ADJOURNMENT

STREETSCAPE & ECONOMIC ENHANCEMENT COMMITTEE MINUTES

Committee Date: Monday, November 1, 2021
Present: Vice-Chair Ald. Michael Curiale, Shashwat Baxi, Mike Melone, Steve Mikos
Absent: Chairperson Ald. Peter Jakab, Linda Lucania
Also Present: Gosia Pociecha, Hailey Nicholas
Meeting Convened at: 6:30 PM

CALL TO ORDER:

Vice-Chairperson Ald. Curiale called the meeting to order at 6:30 pm. Roll call was taken and a quorum was present.

APPROVAL OF THE MINUTES:

Mr. Baxi motioned to approve the minutes of the August 2, 2021 meeting, seconded by Mr. Mikos. The minutes were unanimously approved via voice vote.

NEW BUSINESS:

A. Street Planters - Discussion

Staff explained that the Streetscape and Economic Enhancement Committee has been tasked in identifying desirable locations for placements of large street planters in the City of Wood Dale. Examples from other municipalities were shown, more specifically from Elmwood Park which utilizes urn shaped planters in a street median by the Village Circle. The discussion focused on the shape of planters and it was suggested that staff search if any "prairie style" planters are available. Overall the preferred shape of the planters is round/oval and utilization of smaller and larger sizes was recommended. The Committee also suggested looking into purchase of self-watering planters, or a self-watering system that could be inserted into regular planters. The preferred material is composite in gray/darker colors similar to the black on the entry signs. The suggested location would be in front of the City Hall Entrance, along the sidewalk. Committee suggested getting at least 10 planters, but tasked staff in researching the pricing to see if any discounts are available. Staff is to also verify the available budget for purchase of planters. Three specific styles were identified by the Committee and staff is to reach out

to manufactures to obtain pricing, these included: Luna low bowl, Urban Vase by Earth Planter, and Zena by Tournesol.

OTHER BUSINESS:

B. Future Agenda Items

Brief overview of future discussion topics included the pavilion, solar lighting for entry signs and the status of the clock. It was suggested that park benches and trash cans be added around clock tower.

ADJOURNMENT:

A motion to adjourn was made by Vice-Chairperson Ald. Curiale and seconded by Mr. Malone; it carried unanimously by voice vote. The meeting adjourned at 7:30 pm.

Minutes taken by Gosia Pociecha

CITY OF WOOD DALE

Community Development



MEMO

DATE: Monday, April 4, 2022

TO: Streetscape & Economic Enhancement Committee

FROM: Gosia Pociecha, AICP, Senior Planner

SUBJECT: Planters

OVERVIEW

The Streetscape & Economic Enhancement Committee has been tasked in identifying desirable locations for placement of large street planters in the City of Wood Dale. The topic of discussion will be final recommendation on the type of planters to be selected and location for their installation.

BACKGROUND

During the last Streetscape Committee meeting direction was given to City staff in terms of the shape, color and style of planters that were desirable for the City. Three specific planter styles were identified: Luna low bowl, Urban Vase by Earth Planter, and Zena by Tournesol. It was also suggested to research prairie style planters. The table below shows the individual planter styles, available sizes and pricing.



Luna	Size	Price	Quantity	Total
Small	8" H x 24" W	\$ 251.00*	0	\$ -
Medium	11" H x 36" W	\$ 729.00*	5	\$ 3,645.00
Large	11" H x 47" W	\$ 1,029.00*	10	\$ 10,290.00
			Total	\$ 13,935.00

*Additional reservoir \$89.95 or \$94.85



Zena	Size	Price	Quantity	Total
Medium	18" H x 48" W	\$ 1,009.00	5	\$ 5,045.00
Large	30" H x 48" W	\$ 1,296.00	10	\$ 12,960.00
			Total	\$ 18,005.00



Urban Vase	Size	Price	Quantity	Total
Small (21)	18" H x 21" W	\$ 229.00	5	\$ 1,145.00
Medium (31)	25.75" H x 31" W	\$ 359.00	10	\$ 3,590.00
Large (41)	36" H x 41" W	\$ 539.00	2	\$ 1,078.00
			Total	\$ 4,668.00

Note: Self watering planters

Budget

The Streetscape Committee has an annual budget of \$10,000 for the FY2023 which begins on May 1, 2022.

Locations

In agreement with the Streetscape Committee's suggestion, Staff recommends placement of planters near the City Hall, both in front of the building facing Wood Dale Road, as well in the rear by the parking. The proposed layout shown on the attached aerial photograph includes a combination of ten (10) larger (depicted as blue circles) and five (5) smaller planters (depicted as orange circles).

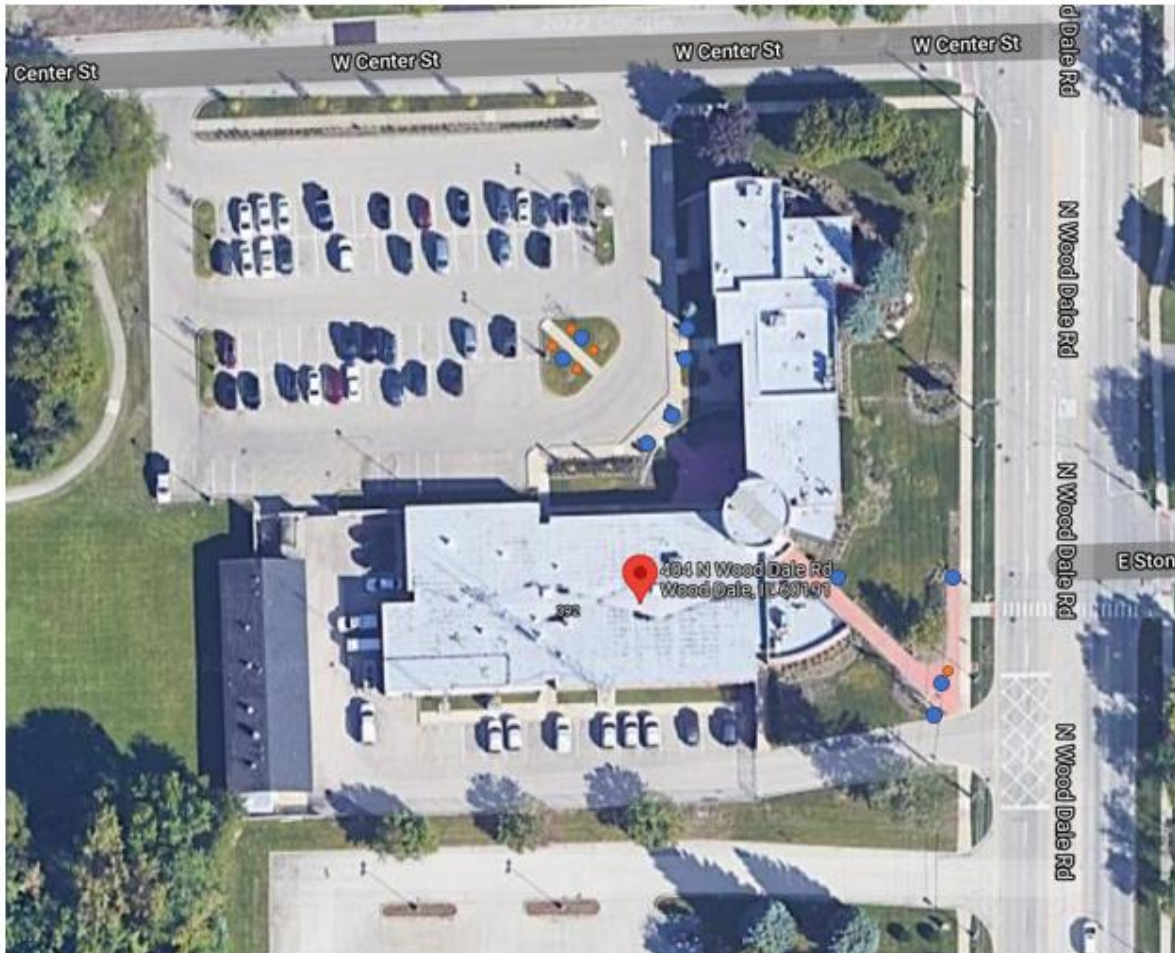

RECOMMENDATION

Staff recommends that the Streetscape and Economic Enhancement Committee recommend approval of the Urban Vase by Earth Planter in the "millstone" color at the locations shown on the attached aerial map with an alternative to adding two largest planters by the rear entrance to the City Hall.

References:

- Planters Unlimited Luna spec sheet
- Tournesol Zena Collection spec sheet
- Earth Planter Urban Vase 31 spec sheet
- Urban Vase 21 Video: <https://www.youtube.com/watch?v=8MQpc4sT4HQ>



2"W x 3"H Trim with
45 degree angle return

2"H Base, corners
are rounded

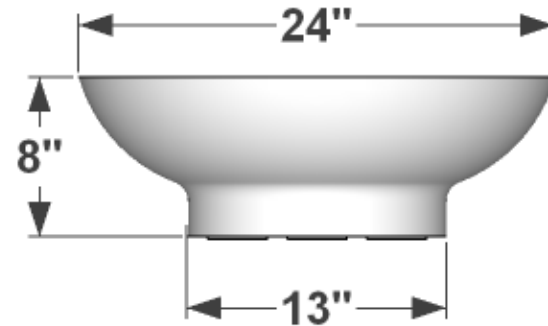

ELEVATION VIEW

PERSPECTIVE VIEW

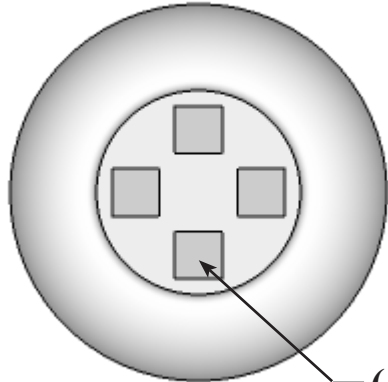

(4) Pads, 3"x3"x1/8"thk.
Offset 1" from edges.

BOTTOM VIEW

General Note: If no drain holes are requested it is assumed proper drainage will be added in the field

Date:
Scale: NTS
DB: GGG
CB:
Rep:
Order#:

Content: Luna Low Bowl Fiberglass Planter
PN: F1-LUN-R2408
Color/Finish:
Customer Approval: _____

Design by Planters Unlimited
All visual representations and designs are the intellectual property of Planters Unlimited and protected under copyright law. Any duplication of this design is in direct violation of the law and will result in legal action. © Copyright 2008-2015

 **PLANTERS UNLIMITED**
By Hooks & Lattice • www.PlantersUnlimited.com
T:888-320-0626 F:760-598-9888

Zena Collection

Materials: **Lightweight GFRC Concrete**

Zena Collection planters have a pronounced, highly-tapered design. The lightweight GFRC concrete is durable enough for high traffic locations yet light enough to be moved. With a wide rim and a narrow waist, the Zena Collection pots can be used as focal points for nearly any streetscape, adding a sleek style to urban environments.



- Applied finishes feature natural quartz and mica sands, and can be refinished and repaired on site as required
- Lightweight GFRC concrete planters have five available textures which range from the rustic to the refined
- Coordinates with our industry-leading self-watering container irrigation products
- Round sizes from 24" to 60"



Rounds

Part. No.	Material	Exterior Size (top x bottom x ht)	Interior Size (top x bottom x ht)	Weight (lbs.)	Soil Volume (cubic ft.)	Matching Irrigation
ZCS-2418	GFRC	24" x 10" x 18"	20" x 8" x 17"	55	1	CWC-1500
ZCS-2400	GFRC	24" x 10" x 24"	20" x 8" x 23"	70	2	CWC-1600
ZCS-3018	GFRC	30" x 11" x 18"	26" x 9" x 17"	60	2	CWM-1114-MS
ZCS-3024	GFRC	30" x 11" x 24"	26" x 9" x 23"	80	3	CWM-1714-MS
ZCS-3000	GFRC	30" x 13" x 30"	26" x 11" x 29"	10	4	CWC-2100/CWM-1120-2k
ZCS-3618	GFRC	36" x 11" x 18"	32" x 9" x 17"	70	3	CWM-1114-MS
ZCS-3624	GFRC	36" x 11" x 24"	32" x 9" x 23"	90	4	CWM-1114-2k
ZCS-3600	GFRC	36" x 14" x 30"	32" x 12" x 29"	115	6	CWM-1720-MS/CWM-1714-2k
ZCS-4818	GFRC	48" x 13" x 18"	44" x 11" x 17"	95	5	CWM-1114-2k
ZCS-4824	GFRC	48" x 13" x 24"	44" x 11" x 23"	120	7	CWM-1714-2k
ZCS-4830	GFRC	48" x 17" x 30"	44" x 15" x 29"	150	11	CWM-1720-2k
ZCS-4800	GFRC	48" x 17" x 36"	44" x 15" x 35"	175	13	CWM-1720-2k
ZCS-6018	GFRC	60" x 16" x 18"	56" x 14" x 17"	130	9	CWM-1714-2k
ZCS-6024	GFRC	60" x 16" x 24"	56" x 14" x 23"	155	12	CWM-1714-3k
ZCS-6036	GFRC	60" x 16" x 24"	56" x 19" x 35"	215	22	CWM-1720-3k
ZCS-6000	GFRC	60" x 21" x 42"	56" x 19" x 41"	240	26	CWM-1720-3k

Note: 1-5/8" drain holes available upon request.

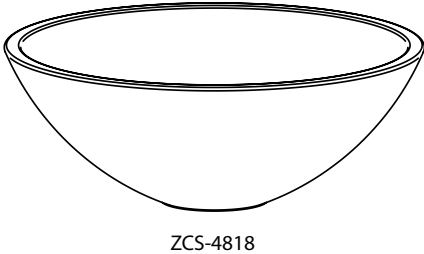
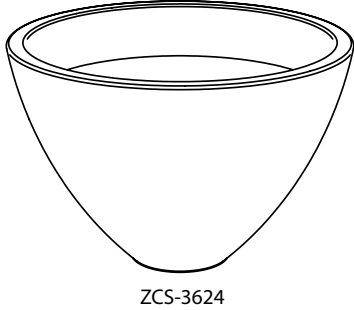
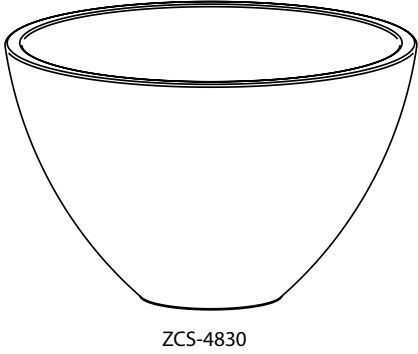
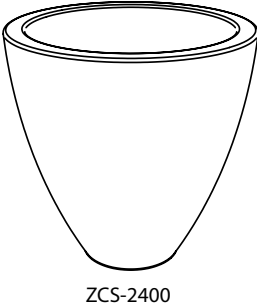

Are you finding everything you need?
If not, let us know - give us a call at 800-542-2282.

ZCS921





EarthPlanter

The Leader in Commercial Self-Watering Planter Systems

Model: EPMV31- Urban Vase



Key Features;

- **Arrives Fully Assembled** – no separate parts, no wicks or wicking material to install
- **Industry Leading Design** – eliminates the need for top watering & delivers superior results in the toughest commercial environments
- **Water Overflow** – internal assembly provides superior protection from over-watering while eliminating unsightly holes, insect intrusion and potential clogging
- **Colors** – highest quality stone effect colors are included at no additional charge

Specifications;

- Dimensions: 31" Top Outside Diameter x 25 ¾" H
- Planting Tray Depth: 13"
- Water Capacity: 18 Gallons
- Product Weight:
 - 23 lbs. (ship weight)
 - 280+ lbs. with water and wet soil
- Soil Capacity: 3.2 Cubic Feet– Pro Mix BX or equivalent soil required
- Watering Cycle: once every 2-3 weeks (mid-summer average)
- Material: LLDPE, Linear Low-Density Polyethylene Embedded with UV Inhibitors to protect against sun fade
- Manufacturing: Rotational Molded for strength & durability
- Colors: Deep Bronze, Brownstone, Sandstone, Millstone, Gray Granite, Blackstone, Rich Terra Cotta
- Stackable: Yes
- Planters per Pallet: up to 10
- Winterized: Yes
- 100% Made in the USA

www.EarthPlanter.com

Phone: 877.815.9276 * Email: sales@earthplanter.com